



GM288 Series

GM288-3

1-Needle, Overedging Industrial Sewing Machine

GM288-4

2-Needle, Overedging Industrial Sewing Machine

GM288-5

Safety Stitch Industrial Sewing Machine

CATALOG

1. FRAME & MISCELLANEOUS COVER COMPONENTS

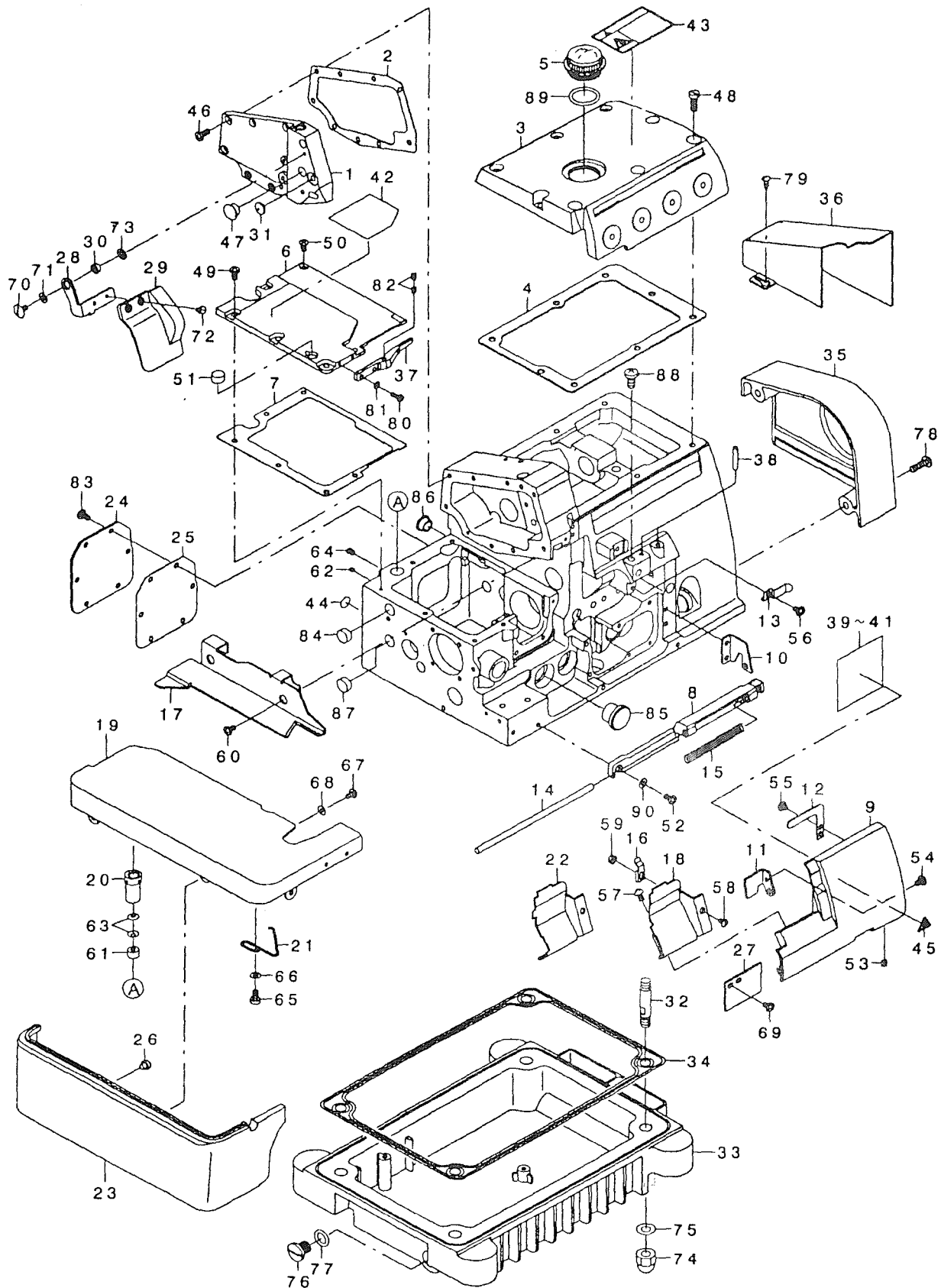

REF NO.	PART NO.	DESCRIPTION	Qty	NOTE	REF NO.	PART NO.	DESCRIPTION	Qty	NOTE
0	8000008	FRAME COMPONENTS	1		46	SM-4041055-SP	SCREW	6	
1	8000107	SIDE COVER	1		47	8107107	BUSHING D PLUG	1	
2	8000206	SIDE COVER GASKET	1		48	8119508	SCREW	8	
3	8000305	UPPER COVER	1		49	SM-4040855-SP	SCREW	5	
4	8000404	UPPER COVER GASKET	1		50	SM-1040801-SP	SCREW M4X0.7 L=8	1	
5	8000503	OIL SIGHT WINDOW	1		51	8106802	CLOTH PLATE RUBBER CUSHION B	1	
6	8000602	FEED MECHANISM COVER	1		52	SM-4041055-SP	SCREW	3	*
7	8000701	GASKET	1		53	SM-8040412-TP	SET SCREW M4 L=4	1	
8	8000800	LOOPER COVER BRACKET	1		54	SM-4040655-SP	SCREW M4 L=6	1	
9	8000909	LOOPER COVER	1		55	8118005	SCREW	1	
10	8001006	LOOPER COVER STOPPER	1		56	SM-4040655-SP	SCREW M4 L=6	1	
11	8001105	GUIDE PLATE	1		57	SM-4040655-SP	SCREW M4 L=6	2	
12	8001204	PRESSER PLATE	1		58	SS-2090520-SL	SCREW 9/64-40 L=5	1	
13	8001303	PRESSER SPRING	1		59	NS-6090310-SN	NUT 9/64-40	1	
14	8001402	HINGE PIN	1		60	SM-4040655-SP	SCREW M4 L=6	2	
15	8001501	LOOPER COVER SPRING	1		61	8100003	CLOTH PLATE HINGE SHAFT COLLAR	1	
16	8001600	CLOTH WASTE COVER STOPPER	1		62	SM-8030312-TP	SCREW M3 L=3	1	
17	8001717	CLOTH PLATE SIDE COVER	1		63	WZ-0420350-KP	DISC SPRING	2	
18	8083004	CLOTH WASTE COVER	1	0 2	64	SM-8040612-TP	SCREW M4 L=6	1	
19	8002764	CLOTH PLATE COMPL.	1		65	SM-6040800-SP	SCREW	2	
20	8002806	ECCENTRIC BUSHING	1		66	WP-0430800-SD	WASHER M4	2	
21	8002905	CLOTH PLATE SPRING	1		67	SM-4040655-SP	SCREW M4 L=6	3	
22	8083202	CLOTH WASTE COVER	1	0 1	68	WP-0430800-SD	WASHER M4	3	
23	8003259	CLOTH PLATE COVER COMPL.	1		69	SM-4040655-SP	SCREW M4 L=6	2	
24	8009009	COVER	1		70	8115308	SCREW	1	
25	8009108	GASKET	1		71	WZ-0850302-KO	WAVED WASHER 8.5X12.5X0.3	1	
26	8002004	RUBBER CUSHION	2		72	SM-6030500-SN	SCREW M3 L=5	2	
27	8003309	CLOTH WASTE COVER (LEFT)	1		73	8111505	WASHER	1	*
28	8003507	EYE GUARD COVER BASE	1		74	8109103	NUT	4	
29	8003705	EYE GUARD COVER	1		75	8111208	WASHER	4	
30	8003804	EYE GUARD COVER BASE COLLAR	1		76	8114103	SCREW	1	
31	8003903	EYE GUARD COVER BASE BUSHING	1		77	RO-1082401-OO	RUBBER RING	1	*
32	8004000	BOLT	4		78	SM-4051655-SP	SCREW M5 L=16	2	
33	8004109	OIL RESERVOIR	1		79	8126008	SCREW	2	
34	8004208	OIL RESERVOIR GASKET	1		80	8124102	SCREW	2	
35	8004307	BELT COVER	1		81	WP-0320501-SD	WASHER	2	
36	8008407	BELT COVER B	1		82	SM-8040412-TP	SET SCREW M4 L=4	2	
37	8004406	THROAT PLATE RETAINER	1		83	SM-4040855-SP	SCREW	6	
38	8004505	THREAD GUIDE(LARGE)	2		84	8107008	RUBBER PLUG	1	
39	8005403	THREADING DIAGRAM	1	0 3	85	8107206	RUBBER PLUG	1	0 2
40	8005502	THREADING DIAGRAM	1	0 4	86	8107107	BUSHING D PLUG	1	
41	8005601	THREADING DIAGRAM	1	0 1	87	8107008	RUBBER PLUG	1	0 2
42	8005700	THREADING DIAGRAM	1	0 1	88	SM-4061255-SP	SCREW M6 L=12	1	
43	8008506	SAFETY LABEL 3 (SMALL)	1		89	RO-2182401-OO	RUBBER RING	1	*
44	8008605	GROUND MARK	1		90	WP-0430800-SD	WASHER M4	3	
45	8008704	ATTENTION SEAL	1		91	8115209	SCREW	3	*

NOTE: 01....FOR GM288-5

03....FOR GM288-3

02....FOR GM288-3, GM288-4

04....FOR GM288-4

2. CRANKSHAFT COMPONENTS

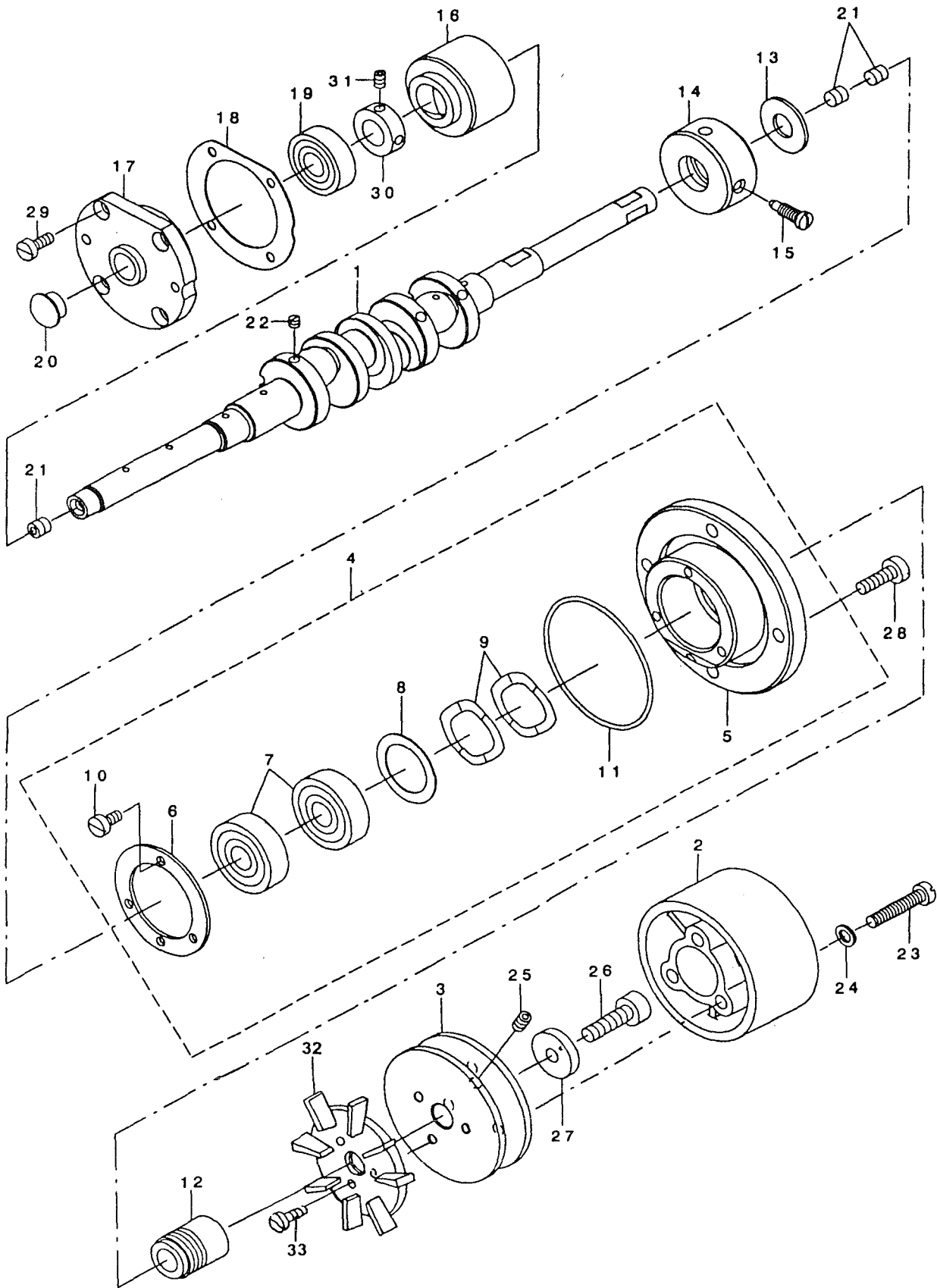

REF NO.	PART NO.	DESCRIPTION	Qty	NOTE
1	8010015	CRANKSHAFT	1	*
2	8010106	HAND WHEEL B	1	
3	8010205	HAND WHEEL A	1	
4	8010353	CRANKSHAFT THRUST COLLAR SAM.	1	
5	8010304	CRANKSHAFT THRUST COLLAR	(1)	
6	8010403	BEARING SUPPORT PLATE	(1)	
7	8104104	CRANKSHAFT BEARING	(2)	
8	8010502	BEARING RECEIVING PLATE	(1)	
9	8112909	WASHER	(2)	
10	SM-6040800-SP	SCREW	(3)	
11	RO-493501-OO	RUBBER RING	(1)	*
12	8010601	OIL SHIELD	1	
13	8010700	BEARING RETAINER	1	
14	8010809	CRANKSHAFT BUSHING B	1	
15	8010908	SCREW	1	
16	8011112	CRANKSHAFT BUSHING C	1	*
17	8011203	CRANKSHAFT BUSHING D	1	
18	8011302	BUSHING D GASKET	1	
19	8104005	BUSHING D BEARING	1	
20	8107107	BUSHING D PLUG	1	0 1
21	SM-8060612-TP	SCREW M6 L=6	3	
22	SM-8040310-SS	SCREW M4 L=3	4	
23	8119706	SCREW	3	
24	8110606	WASHER	3	
25	SM-8061212-TP	SCREW M6 L=12	2	
26	SM-6061602-TP	SCREW M6 L=16	1	
27	8111000	WASHER	1	
28	SM-6051600-SP	SCREW M5 L=16	4	
29	SM-6041000-SP	SCREW M4 L=10	4	
30	8100300	SLIDE BLOCK COLLAR	1	0 1
31	SM-8040412-TP	SET SCREW M4 L=4	2	0 1
32	8011500	LEAF WIND	1	
33	8121207	SCREW	3	

NOTE: 01... FOR GM288-3, GM288-4

3. NEEDLE DRIVING SHAFT COMPONENTS

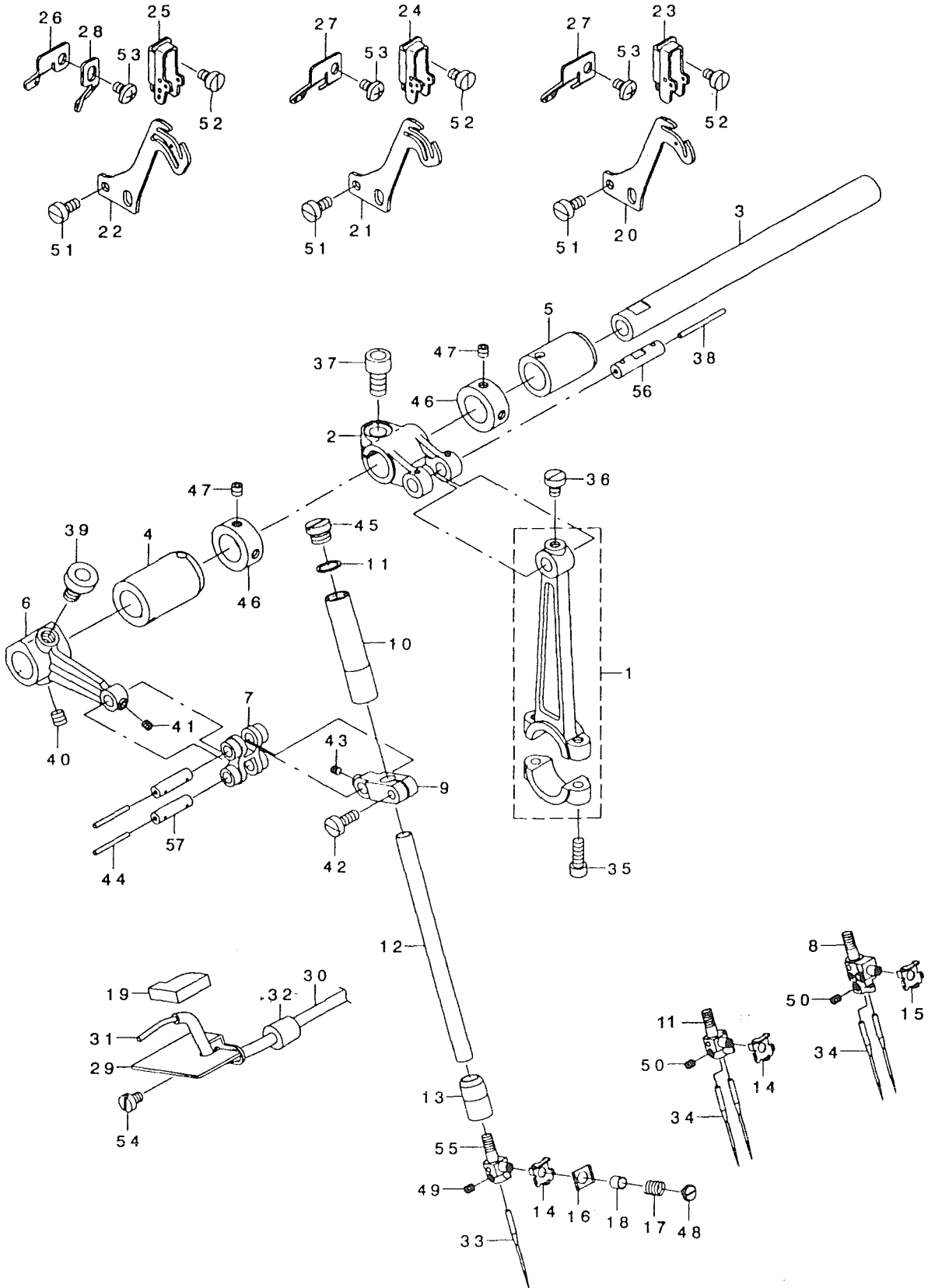

REF NO.	PART NO.	DESCRIPTION	Qty	NOTE
1	8012508	NEEDLE DRIVING ROD	1	
2	8012607	NEEDLE DRIVING FORKED CRANK	1	
3	8012805	NEEDLE DRIVING SHAFT	1	
4	8012904	BUSHING , FRONT	1	
5	8013001	BUSHING , REAR	1	
6	8013209	NEEDLE DRIVING ARM	1	
7	8013308	NEEDLE DRIVING LINK	1	
8	8065407	NEEDLE CLAMP , CHAIN LOOPER	1	0 2
9	8013506	NEEDLE BAR HOLDER	1	
10	8013605	NEEDLE BAR BUSHING , UPPER	1	
11	8065100	NEEDLE CLAMP , 2-NEEDLE	1	0 4
12	8013803	NEEDLE BAR	1	
13	8013902	NEEDLE BAR BUSHING , LOWER	1	
14	8016103	NEEDLE THREAD PRESSER GUIDE A	1	0 1
15	8014009	NEEDLE THREAD PRESSER GUIDE	1	0 2
16	8014207	NEEDLE THREAD PRESSER PLATE A	1	
17	8014405	NEEDLE THREAD PRESSER SPRING	1	
18	8014504	THREAD GUIDE COLLAR	1	
19	8015709	FELT	2	
20	8014603	TAKE-UP LEVER	1	0 3
21	8014702	TAKE-UP LEVER , 2-NEEDLE	1	0 4
22	8014801	TAKE-UP LEVER , CHAIN LOOP	1	0 2
23	8014900	NEEDLE THREAD GUIDE	1	0 3
24	8015006	NEEDLE THREAD GUIDE , 2-NEEDLE	1	0 4
25	8015105	THREAD GUIDE , CHAIN LOOP	1	0 2
26	8015303	TAKE-UP LEVER GUIDE	1	0 2
27	8015402	TAKE-UP LEVER GUIDE , 2-NEEDLE	1	0 1
28	8015501	TAKE-UP LEVER GUIDE , CHAIN LOOP	1	0 2
29	8015600	COVER	1	
30	BP-3000001-OO	VINYL TUBE	0.31	
31	CQ-2000000-OO	OIL WICK	0.32	
32	8107503	PLUG	1	*
33	MDC-270B11-OO	NEEDLE DCX27#11	1	0 3
34	MDC-270B11-OO	NEEDLE DCX27#11	2	0 5
35	SM-6041202-TP	SCREW M4X0.7 L=12	2	
36	SM-6040600-SP	SCREW M4 L=6	1	
37	SM-6061202-TP	SCREW M6 L=12	1	
38	CQ-2000000-OO	OIL WICK	0.05	
39	SM-6061002-TP	SCREW M6 L=10	1	
40	SM-8050502-TP	SCREW M5 L=5	1	
41	SM-8030312-TP	SCREW M3 L=3	1	
42	SM-6041000-SP	SCREW M4 L=10	1	
43	SM-8030312-TP	SCREW M3 L=3	1	
44	CQ-2000000-OO	OIL WICK	0.04	
45	8120605	SCREW	1	
46	8100409	THRUST COLLAR	2	
47	SM-8040412-TP	SET SCREW M4 L=4	4	
48	8117205	SCREW	1	
49	SM-8030312-TP	SCREW M3 L=3	1	0 3
50	SM-8030312-TP	SCREW M3 L=3	2	0 5
51	SM-6040800-SP	SCREW	2	
52	SM-6040600-SP	SCREW M4 L=6	2	
53	SM-4040655-SP	SCREW M4 L=6	1	
54	8118104	SCREW	2	
55	8065001	NEEDLE CLAMP	1	0 3
56	80162A0	CRANK PINA	1	
57	80120A1	LINK PIN C	2	

NOTE: 01....FOR GM288-3, GM288-4 03....FOR GN288-3 05....FOR GM288-4, GM288-5
02....FOR GM288-5 04....FOR GM288-4 06....FOR SELECTIVE PART

4. PRESSER FOOT COMPONENTS (1)

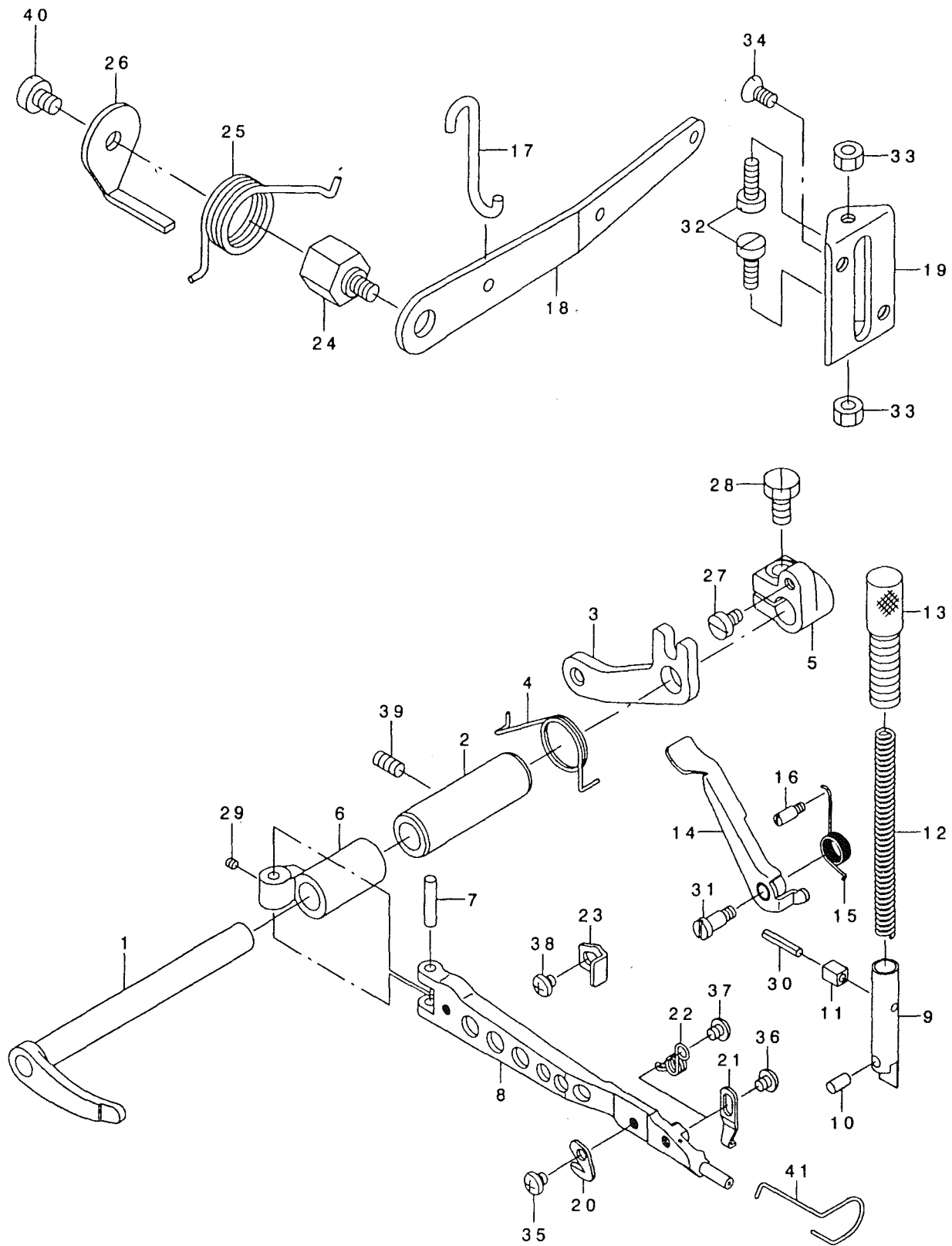

REF NO.	PART NO.	DESCRIPTION	Qty	NOTE
1	8017507	PRESSER FOOT SHAFT	1	
2	8017606	BUSHING	1	
3	8017705	LIFTING ARM	1	
4	8017804	SPRING	1	
5	8017903	THRUST ARM	1	
6	8018000	PRESSER FOOT SHAFT ARM	1	
7	8018109	PRESSER FOOT ARM HINGE SHAFT	1	
8	8018208	PRESSER FOOT ARM	1	
9	8018414	PRESSER BAR	1	
10	8018513	PRESSER BAR BLOCK	1	
11	8018604	LIFTING PIN BLOCK	1	
12	8018703	PRESSER SPRING	1	
13	8018802	PRESSER REGULATOR SCREW	1	
14	8018950	PRESSER LIFTING LEVER SAM.	1	
15	8019107	SPRING	1	
16	8019206	STOPPER	1	
17	8019305	LEVER HOOK	1	
18	8019404	PRESSER FOOT LIFTING LEVER	1	
19	8019503	STOPPER PLATE	1	
20	8019602	THREAD TRIMMER	1	
21	8019701	STOPPER	1	0 1
22	8019800	PRESSER FOOT ARM SPRING	1	0 2
23	8020006	STOPPER	1	
24	8020105	HINGE SCREW	1	
25	8020204	LIFTING LEVER SPRING	1	
26	8020303	LIFTING LEVER SPRING HOOK	1	
27	SS-6110710-TP	SCREW 11/64-40 L=6.5	1	
28	SS-9151210-TP	SCREW 15/64-28 L=11.8	1	
29	SM-8030312-TP	SCREW M3 L=3	1	
30	8101506	PRESSER BAR LIFTING PIN	1	
31	8113600	HINGE SCREW	1	
32	SM-6051400-SP	SCREW	2	
33	NM-6050001-SP	NUT M5	2	
34	8121207	SCREW	2	
35	8118005	SCREW	1	
36	8118005	SCREW	1	0 1
37	8118005	SCREW	1	0 2
38	8118005	SCREW	1	
39	SM-8051002-TP	SCREW M5 L=10	1	
40	SM-6060800-SP	SCREW M6 L=8	1	
41	8067700	FINGER GUARD	1	

NOTE: 01...FOR GM288-3. GM288-4 02 FOR GM288-5

5. PRESSER FOOT COMPONENTS (2)

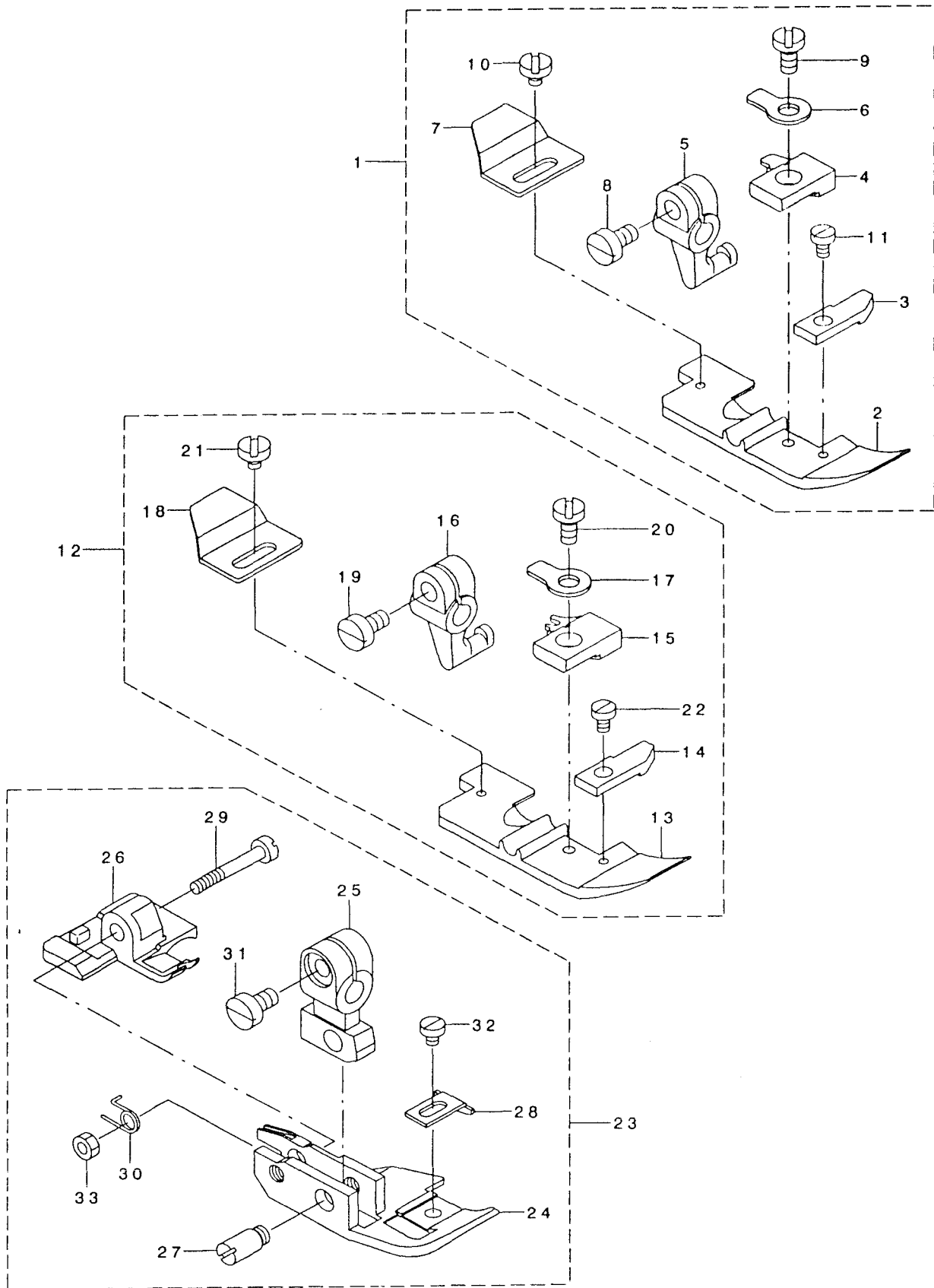

REF NO.	PART NO.	DESCRIPTION	Qty	NOTE
1	8066058	PRESSER FOOT SAM.	1	0 1
2	8067007	PRESSER FOOT	(1)	
3	8067160	CURL GUARD	(1)	
4	8067205	STITCH TONGUE	(1)	
5	8067304	PRESSER FOOT HINGE	(1)	
6	8067403	SPRING	(1)	
7	8067502	REAR PRESSER FOOT	(1)	
8	SS-6090670-TP	SCREW 9/64-40 L=6	(1)	*
9	8116306	SCREW	(1)	
10	8116207	SCREW	(1)	
11	SS-6060410-TP	SCREW 3/32-56 L=3.5	(1)	
12	8066553	PRESSER FOOT SAM.	1	0 2
13	8067809	PRESSER FOOT	(1)	
14	8067106	CURL GUARD	(1)	
15	8067908	STITCH TONGUE	(1)	
16	8067304	PRESSER FOOT HINGE	(1)	
17	8067403	SPRING	(1)	
18	8067502	REAR PRESSER FOOT	(1)	
19	SS-6090670-TP	SCREW 9/64-40 L=6	(1)	*
20	8116306	SCREW	(1)	
21	8116207	SCREW	(1)	
22	SS-6060410-TP	SCREW 3/32-56 L=3.5	(1)	
23	8070050	PRESSER FOOT SAM.	1	0 3
24	8071009	PRESSER FOOT	(1)	
25	8071108	PRESSER FOOT HINGE	(1)	
26	8071207	REAR PRESSER FOOT	(1)	
27	8071306	HINGE PIN	(1)	
28	8071405	CLOTH PRESSER	(1)	
29	8071504	HINGE SCREW	(1)	
30	8071603	SPRING	(1)	
31	SS-6090670-TP	SCREW 9/64-40 L=6	(1)	*
32	SS-6060340-SP	SCREW 3/32-56 L=2.5	(1)	
33	NS-6080210-SP	NUT 1/8-44	(1)	

NOTE: 01...FOR GM288-3
02...FOR GM288-4
03...FOR GM288-5

6. FEED MECHANISM COMPONENTS (1)

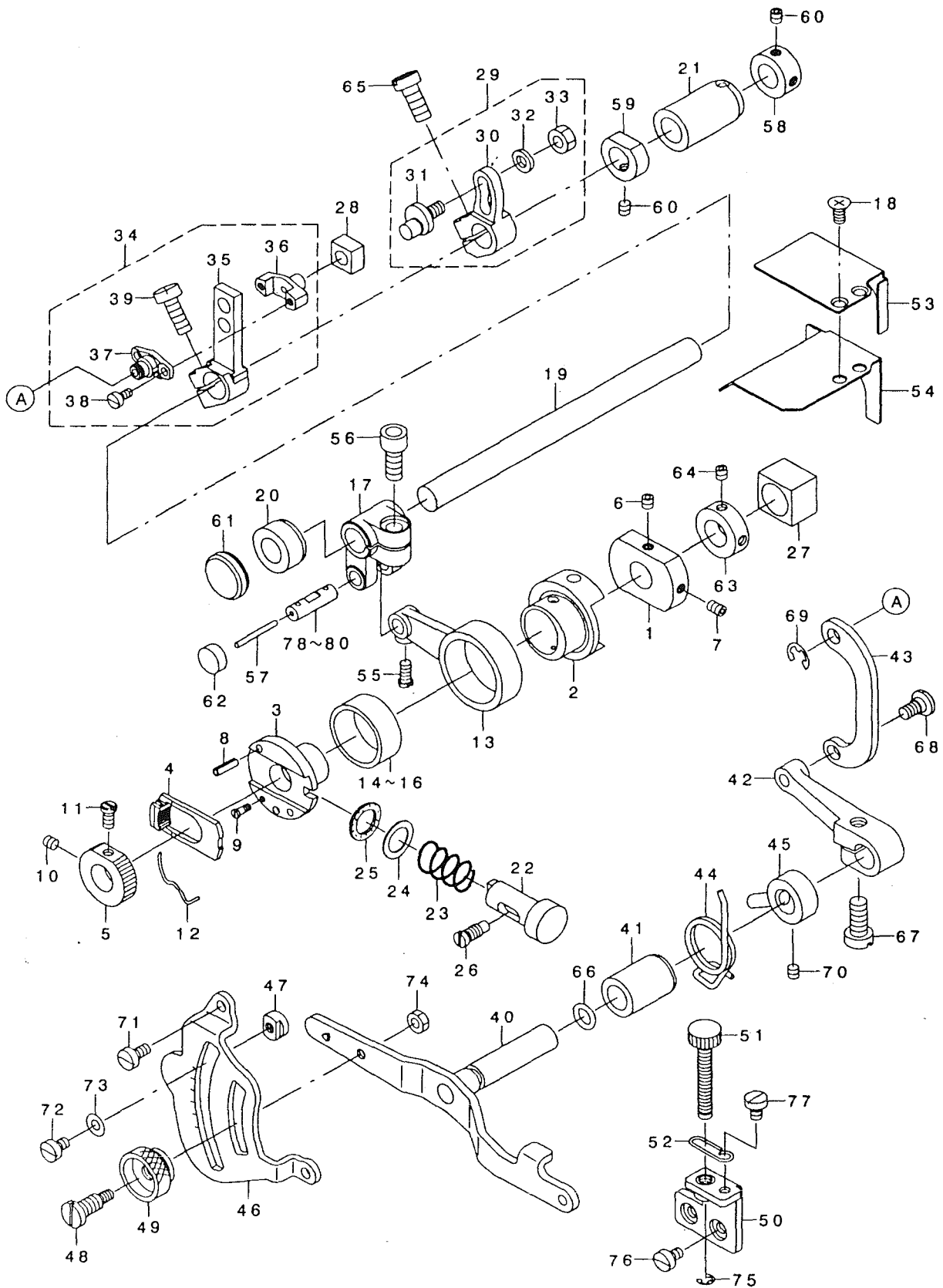

REF NO.	PART NO.	DESCRIPTION	Qty	NOTE	REF NO.	PART NO.	DESCRIPTION	Qty	NOTE
1	8021004	FEED ECCENTRIC BODY	1		43	8024909	DIFFERENTIAL FEED LINK	1	
2	8021103	FEED CAM	1		44	8025005	SPRING	1	
3	8021301	FEED ADJUSTING CAM	1		45	8025153	SPRING HOOK SAM.	1	
4	8021509	RATCHET PAWL	1		46	8025203	DIFFERENTIAL FEED GRADUATION	1	
5	8021608	RATCHET GEAR	1		47	8025302	STOPPER	2	
6	SM-8040412-TP	SET SCREW M4 L=4	1		48	8025401	HINGE SCREW	1	
7	SM-8040612-TP	SCREW M6 L=6	1		49	8025500	LOCK NUT	1	
8	8101407	FEED REGULATING PIN	2		50	8025609	SCREW BASE SAM.	1	*
9	8117301	SCREW	1		51	8025807	SCREW	1	
10	SM-8040412-TP	SET SCREW M4 L=4	1		52	8025906	ROTATION STOPPER	1	
11	8118203	RATCHET GEAR SET SCREW B	1		53	8026615	OIL SHIELD A	1	*
12	B1606-704-000	RATCHET PAWL SPRING	1		54	8026714	OIL SHIELD B	1	*
13	8021806	FEED CRANK ROD	1		55	8115100	SCREW	1	
14	8021905	FEED BEARING A	1	01	56	SM-6061402-TP	SCREW M6 L=14	1	
15	8022002	FEED BEARING B	1	01	57	CQ-2000000-OO	OIL WICK	0.04	
16	8022101	FEED BEARING C	1	01	58	8100201	THRUST COLLAR	1	
17	8022200	FORKED CRANK	1		59	8027308	THRUST COLLAR . THIN	1	
18	SM-1040801-SP	SCREW MAXO. 7 L=8	2		60	SM-8040412-TP	SET SCREW M4 L=4	3	
19	8022408	FEED SHAFT	1		61	8107305	RUBBER PLUG	1	
20	8022507	FEED SHAFT BUSHING . FRONT	1		62	8106901	RUBBER PLUG D=10.3 L=4	1	*
21	8022606	FEED SHAFT BUSHING . REAR	1		63	8116504	SCREW	1	*
22	8027803	PUSH BUTTON SHAFT	1	*	64	RO-0952001-OO	RUBBER RING	1	*
23	8022804	PUSH BUTTON SPRING	1		65	8120407	SCREW	1	
24	8022903	WASHER	1		66	8103205	RUBBER RING	1	
25	8027902	PUSH BUTTON SHAFT B	1	*	67	8120407	SCREW	1	
26	8023117	PUSH BUTTON SHAFT SCREW	1	*	68	8113808	HINGE SCREW	1	
27	8023216	SLIDE BLOCK	1	*	69	RE-0500000-KO	E-RING	1	
28	8023703	DIFFERENTIAL FEED SLIDE BLOCK	1		70	SM-8040412-TP	SET SCREW M4 L=4	2	
29	8023851	MAIN FEED ROCKER SAM.	1		71	SM-6040800-SP	SCREW	2	
30	8023802	MAIN FEED ROCKER	(1)		72	SM-6040600-SP	SCREW M4 L=6	2	
31	8027001	PIN	(1)		73	WP-0450701-SD	WASHER 4.5x10x0.8	2	
32	8027100	WASHER	(1)		74	NM-6040003-SD	NUT M4	1	
33	NS-6620320-SP	NUT 3/16-32	(1)		75	RE-0300000-KO	E-RING 3	1	
34	8023950	DIFFERENTIAL FEED ROCKER SAM.	1		76	SM-6040600-SP	SCREW M4 L=6	2	
35	8023901	DIFFERENTIAL FEED ROCKER	(1)		77	SM-6040600-SP	SCREW M4 L=6	1	
36	8024008	PIN	(1)		78	8027407	FORKED CRANK PIN A	1	01
37	8024107	PIN COVER	(1)		79	8027506	FORKED CRANK PIN B	1	01
38	SM-6030600-SP	SCREW M3X0.5 L=6	(2)		80	8027605	FORKED CRANK PIN C	1	01
39	8120407	SCREW	(1)		81	8027704	OIL SHIELD	1	*
40	8024552	DIFFERENTIAL FEED SHAFT SAM.	1		82	SM-6040600-SP	SCREW M4 L=6	2	*
41	8024701	BUSHING	1		83	SS-5060310-SP	SCREW 3/32-56 L=2.8	2	*
42	8024800	DIFFERENTIAL FEED ARM	1						

NOTE: 01....FOR SELECTIVE PART

7. FEED MECHANISM COMPONENTS (2)

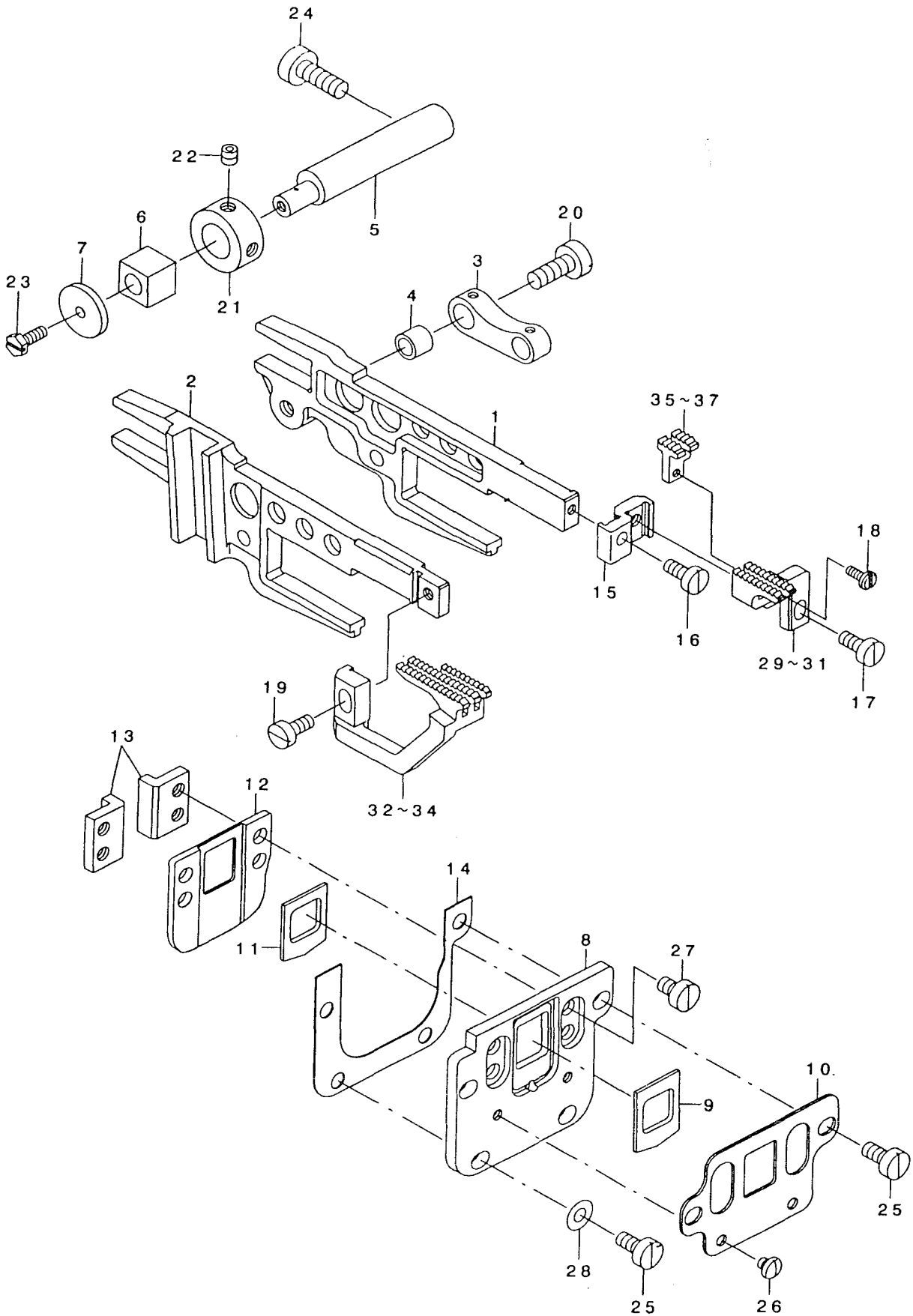

REF NO.	PART NO.	DESCRIPTION	Qty	NOTE
1	8023356	FEED BAR SAM.	1	*
2	8023505	DIFFERENTIAL FEED BAR	(1)	
3	8023307	MAIN FEED BAR	(1)	
4	8027209	MAIN FEED LINK COLLAR	1	
5	8024214	FEED BAR SHAFT	1	*
6	8024305	SLIDE BLOCK	1	
7	8024404	WASHER	1	
8	8026003	DUST GUARD RUBBER CASE	1	
9	8026102	DUST GUARD RUBBER	1	
10	8026201	PRESSER PLATE	1	
11	8026300	OIL SHIELD RUBBER	1	
12	8026417	PRESSER PLATE	1	*
13	8026508	FEED BAR SUPPORT	2	
14	8026904	DUST GUARD RUBBER CASE GASKET	1	
15	8026805	MAIN FEED DOG INSTALLING BASE	1	
16	SS-6090810-TP	SCREW 9/64-40 L=7.5	1	
17	SS-6090810-TP	SCREW 9/64-40 L=7.5	1	
18	8116009	SCREW	1	
19	SS-6090810-TP	SCREW 9/64-40 L=7.5	1	
20	SS-6121220-TP	SCREW 3/16-28 L=11.5	1	
21	8100102	THRUST COLLAR	1	*
22	SM-8040412-TP	SET SCREW M4 L=4	1	
23	8124102	SCREW	1	
24	SM-6051400-SP	SCREW	1	
25	SM-6041000-SP	SCREW M4 L=10	4	*
26	8117520	SCREW	2	
27	SM-4040755-SP	SCREW	4	*
28	WP-0430800-SD	WASHER M4	2	
29	8076008	MAIN FEED DOG	1	01
30	8076107	MAIN FEED DOG	1	02
31	8076206	MAIN FEED DOG	1	03
32	8078004	DIFFERENTIAL FEED DOG	1	01
33	8078103	DIFFERENTIAL FEED DOG	1	02
34	8078202	DIFFERENTIAL FEED DOG	1	03
35	8080000	AUXILIARY FEED DOG	1	01
36	8080109	AUXILIARY FEED DOG	1	02
37	8080208	AUXILIARY FEED DOG	1	03
38	8023604	MAIN FEED LINK	1	

NOTE:

01....FOR GM288-3

02....FOR GM288-4

03....FOR GM288-5

8. CHAIN LOOPER COMPONENTS (FOR GN880-5)

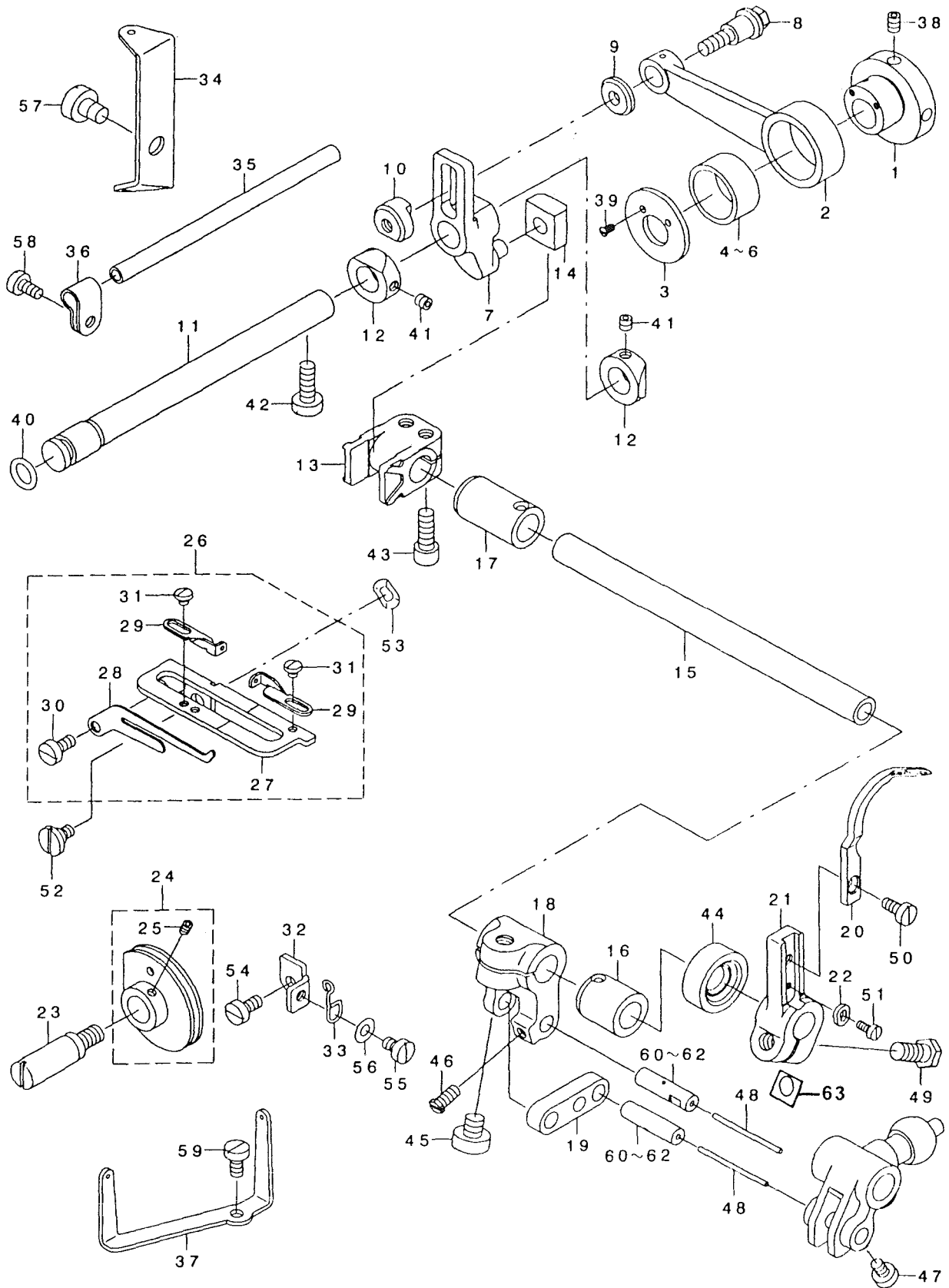

REF NO	PART NO	DESCRIPTION	Qty	NOTE	REF NO.	PART NO.	DESCRIPTION	Qty	NOTE
1	8028009	CHAIN LOOPER ECCENTRIC CAM	1		33	8031102	THREAD GUIDE BASE STOPPER	1	
2	8028108	CHAIN LOOPER ROD	1		34	8031201	LOOPER THREAD CONDUIT GUIDE	1	
3	8028207	ECCENTRIC CAM COVER	1		35	8031300	LOOPER THREAD CONDUIT	1	
4	8028306	CHAIN LOOPER ROD BEARING A	1	01	36	8031409	INSTALLING BASE	1	
5	8028405	CHAIN LOOPER ROD BEARING B	1	01	37	8031508	LOOPER THREAD GUIDE	1	
6	8028504	CHAIN LOOPER ROD BEARING C	1	01	38	SM-8040612-TP	SCREW M4 L=6	2	
7	8028603	CHAIN LOOPER SHAFT SLIDE ARM	1		39	8116108	SCREW	2	
8	8028702	HINGE SCREW	1		40	8103106	RUBBER RING	1	*
9	8028801	WASHER	1		41	SM-8040412-TP	SET SCREW M4 L=4	2	
10	8031607	NUT	1		42	SM-6051400-SP	SCREW	1	
11	8028900	CHAIN LOOPER SHAFT	1		43	SM-6051402-TP	SCREW M5X0.8 L=14	2	
12	8029007	CHAIN LOOPER SHAFT THRUST	2		4	8105507	OIL SEAL RING	1	
13	8029106	SLIDE BLOCK BRACKET	1		45	SM-6061402-TP	SCREW M6 L=14	1	
14	8029205	CHAIN LOOPER SLIDE BLOCK	1		46	8115100	SCREW	1	
15	8029304	CHAIN LOOPER SHAFT	1		47	SM-6040600-SP	SCREW M6 L=6	1	
16	8029403	BUSHING , FRONT	1		48	CQ-2000000-OO	OIL WICK	0.1	
17	8029502	BUSHING , REAR	1		49	8125208	SCREW	1	
18	8029601	CHAIN LOOPER SHAFT DRIVING ARM	1		50	SS-6090810-SP	SCREW 9/64-40 L=7.5	1	
19	8029700	DRIVING LINK	1		51	SM-6850600-SP	SCREW	1	
20	8082600	CHAIN LOOPER	1		52	8113907	HINGE SCREW	1	
21	8029908	CHAIN LOOPER DRIVING ARM	1		53	WZ-0641510-KP	WAVED WASHER 6.4X11X0.3	1	
22	8030005	LOWER LOOPER STOPPER	1		54	SM-6040800-SP	SCREW	1	
23	8030104	LOOPER THREAD CAM SHAFT	1		55	SM-6040600-SP	SCREW M4 L=6	1	
24	8030250	LOOPER THREAD CAM SAM.	1		56	WP-0430800-SD	WASHER M4	1	
25	SM-8030312-TP	SCREW M3 L=3	(2)		57	SM-6060800-SP	SCREW M6 L=8	1	
26	8030559	THREAD GUIDE SAM.	1		58	SM-6040800-SP	SCREW	1	
27	8030658	THREAD GUIDE BASE SAM.	(1)		59	SM-6040800-SP	SCREW	1	
28	8030807	LOOPER THREAD CAM CLAW	(1)		60	8031706	DRIVING LINK PIN A	2	01
29	8030906	THREAD GUIDE	(2)		61	8031805	DRIVING LINK PIN B	2	01
30	SM-6040800-SP	SCREW	(1)		62	8031904	DRIVING LINK PIN C	2	01
31	8117502	SCREW	(2)		63	8035301	WASHER	1	*
32	8031003	THREAD GUIDE BASE STOPPER BAS	1						

NOTE: 01... FOR SELECTIVE PART

9. UPPER & LOWER LOOPER COMPONENTS

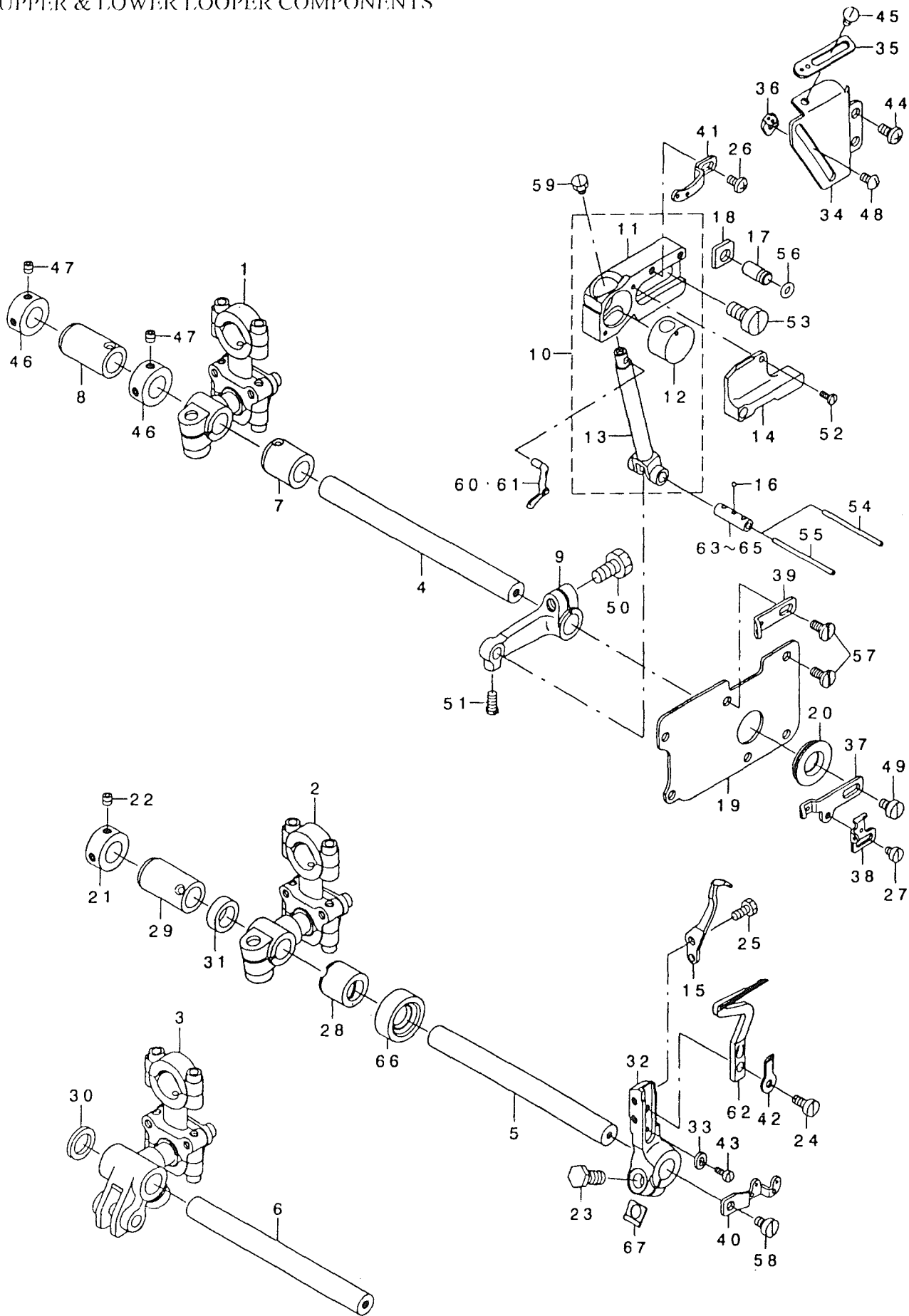

REF NO.	PART NO.	DESCRIPTION	Qty	NOTE	REF NO.	PART NO.	DESCRIPTION	Qty	NOTE
1	8033157	UPPER LOOPER BALL HOLDER SAM.	1	*	35	8040303	THREAD GUIDE , RIGHT	1	
2	8035558	BALL HOLDER A SAM.	1	* 0 1	36	8040808	THREAD GUIDE	1	
3	8035657	BALL HOLDER B SAM.	1	* 0 2	37	8040402	THREAD TAKE-UP , RIGHT	1	
4	8034205	LOOPER SHAFT	1	*	38	8040709	LOWER LOOPER THREAD TAKE-UP	1	
5	8033306	UPPER LOOPER SHAFT	1	0 1	39	8036507	THREAD GUIDE , MIDDLE	1	
6	8035103	LOWER LOOPER SHAFT	1	0 2	40	8040907	LOWER THREAD GUIDE , LEFT	1	
7	8029403	BUSHING , FRONT	1		41	8040501	THREAD GUIDE , UPPER	1	
8	8029502	BUSHING , REAR	1		42	8036804	THREAD GUIDE , LEFT	1	
9	8033405	LOOPER HOLDER	1		43	SM-6850600-SP	SCREW	1	
10	8033553	LOOPER GUIDE SUPPORT SAM.	1		44	SM-4040855-SP	SCREW	2	
11	8033504	UPPER LOOPER GUIDE SUPPORT	(1)		45	SS-3090610-SP	SCREW 9/64-40 L=6	1	
12	8073108	UPPER LOOPER GUIDE	(1)		46	8100201	THRUST COLLAR	2	
13	8033702	UPPER LOOPER HOLDER	(1)		47	SM-8040412-TP	SET SCREW M4 L=4	4	
14	8033801	UPPER LOOPER GUIDE COVER	1		48	SS-3090610-SP	SCREW 9/64-40 L=6	1	
15	8084002	TRAVELING NEEDLE GUARD	1		49	SM-6040600-SP	SCREW M4 L=6	1	
16	8034403	OIL WICK STOP BALL	1		50	SM-9061250-TP	SCREW M6 L=12	1	
17	8034502	PIN	1		51	8115100	SCREW	1	
18	8034601	GAUGE	1		52	SS-7060610-SP	SCREW 3/32-56 L=5.5	2	
19	8034700	OIL SHIELD	1		53	SM-6061200-SP	SCREW	2	
20	8034809	UPPER LOOPER SHAFT RUBBER RING	1		54	CQ-2000000-OO	OIL WICK	0.04	
21	8100201	THRUST COLLAR	1	*	55	CQ-2020000-OO	OIL WICK	0.04	
22	SM-8040412-TP	SET SCREW M4 L=4	2	*	56	8103007	RUBBER RING	1	
23	8125208	SCREW	1		57	8115209	SCREW	6	
24	SS-6090810-TP	SCREW 9/64-40 L=7.5	1		58	SM-6040600-SP	SCREW M4 L=6	1	
25	8116405	SCREW	2		59	SS-9090410-TP	SCREW	1	
26	SS-4090615-SP	SCREW 9/64-40 L=6	1		60	8081107	UPPER LOOPER	1	0 3
27	SS-6080410-SP	SCREW 1/8-44 L=4	1		61	8081008	UPPER LOOPER	1	0 4
28	8034908	BUSHING , FRONT	1	*	62	8081800	LOWER LOOPER	1	
29	8029502	BUSHING , REAR	1		63	8033900	UPPER LOOPER HOLDER PIN A	1	0 5
30	8035707	SPACER	1	0 2	64	8034007	UPPER LOOPER HOLDER PIN B	1	0 5
31	8035202	SPACER	1	0 1	65	8034106	UPPER LOOPER HOLDER PIN C	1	0 5
32	8035806	LOWER LOOPER ARM	1		66	8105507	OIL SEAL RING	1	
33	8030005	LOWER LOOPER STOPPER	1		67	8035301	WASHER	1	*
34	8040204	LOOPER THREAD TAKE-UP COVER	1						

NOTE: 01 ... FOR GM288-3, GM288-4
02 ... FOR GM288-5
03 ... FOR GM288-3, GM288-5
04 ... FOR GM288-4
05 ... FOR SELECTIVE PART

10. THREAD TENSION COMPONENTS

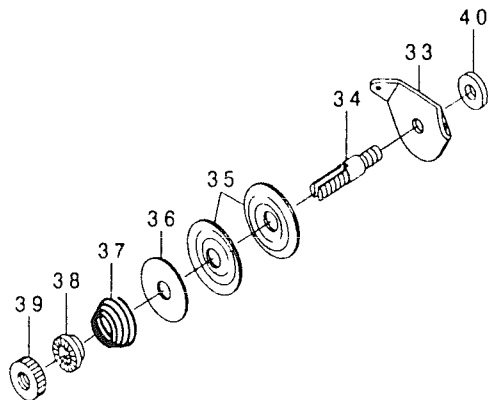
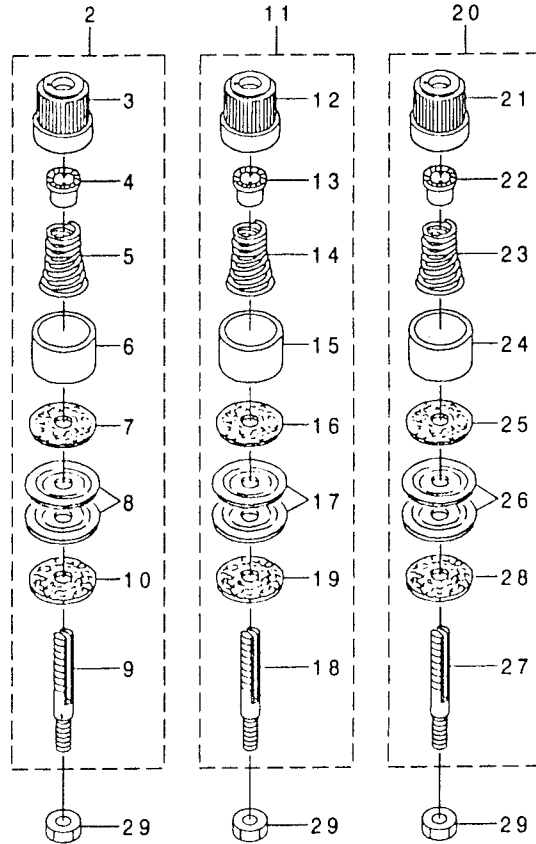
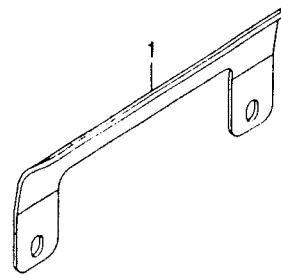
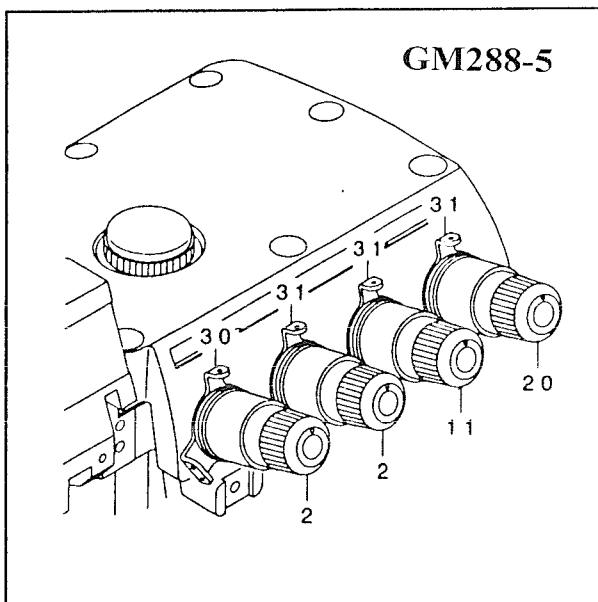
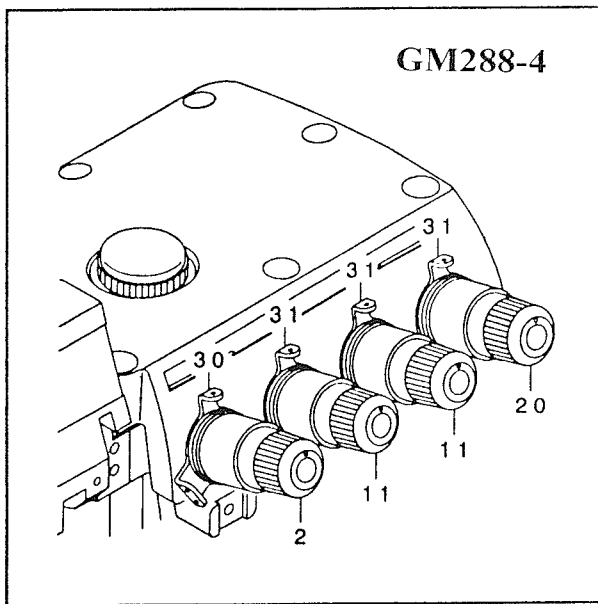
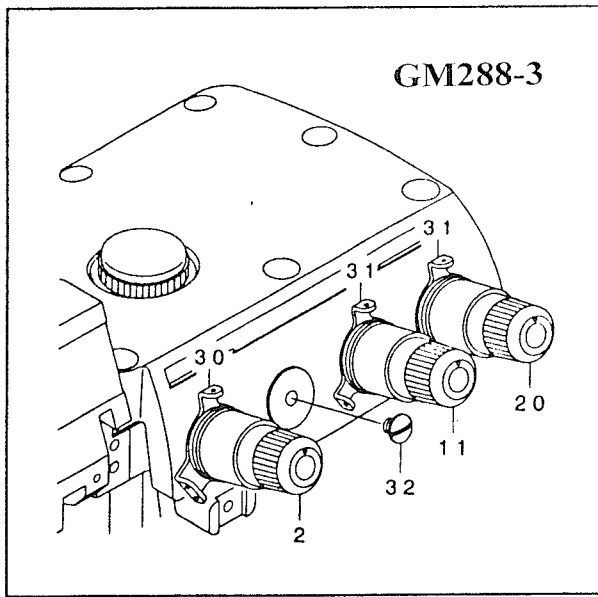

REF NO.	PART NO.	DESCRIPTION	Qty	NOTE
1	8038008	CENTER THREAD GUIDE	1	
2	8038156	TENSION SPRING SAM. , RED	1	
3	8285003	THREAD TENSION KNOB , RED	(1)	
4	8285508	TENSION SPRING BUSHING	(1)	
5	8284709	TENSION SPRING , RED	(1)	
6	8285409	TENSION DISK PRESSER	(1)	
7	8285607	THREAD TENSION SPRING FELT	(1)	
8	8285706	THREAD TENSION DISK	(2)	
9	8239402	TENSION POST	(1)	
10	8285805	THREAD TENSION RUBBER	(1)	
11	8038255	TENSION SPRING SAM. , YELLOW	1	
12	8285102	THREAD TENSION KNOB , YELLOW	(1)	
13	8285508	TENSION SPRING BUSHING	(1)	
14	8284808	TENSION SPRING , YELLOW	(1)	
15	8285409	TENSION DISK PRESSER	(1)	
16	8285607	THREAD TENSION SPRING FELT	(1)	
17	8285706	THREAD TENSION DISK	(2)	
18	8239402	TENSION POST	(1)	
19	8285805	THREAD TENSION RUBBER	(1)	
20	8038354	TENSION SPRING SAM. , BLUE	1	
21	8285201	THREAD TENSION KNOB , BLUE	(1)	
22	8285508	TENSION SPRING BUSHING	(1)	
23	8284907	TENSION SPRING , BLUE	(1)	
24	8285409	TENSION DISK PRESSER	(1)	
25	8285607	THREAD TENSION SPRING FELT	(1)	
26	8285706	THREAD TENSION DISK	(2)	
27	8239402	TENSION POST	(1)	
28	8285805	THREAD TENSION RUBBER	(1)	
29	8108006	NUT	1	
30	8039501	THREAD GUIDE	1	
31	8039600	THREAD GUIDE	1	
32	8119300	SCREW	1	02
33	8039709	THREAD GUIDE	1	01
34	8039808	TENSION POST	1	01
35	8039303	THREAD TENSION DISK	2	01
36	8039204	THREAD TENSION FELT	1	01
37	8039907	TENSION SPRING	1	01
38	8038701	ROTATING STOPPER	1	01
39	8040004	NUT	1	01
40	8110705	THREAD TENSION COLLAR	1	01

NOTE:

01....FOR GM288-5

02....FOR GM288-3

11. LUBRIATION MECHANISM COMPONENTS

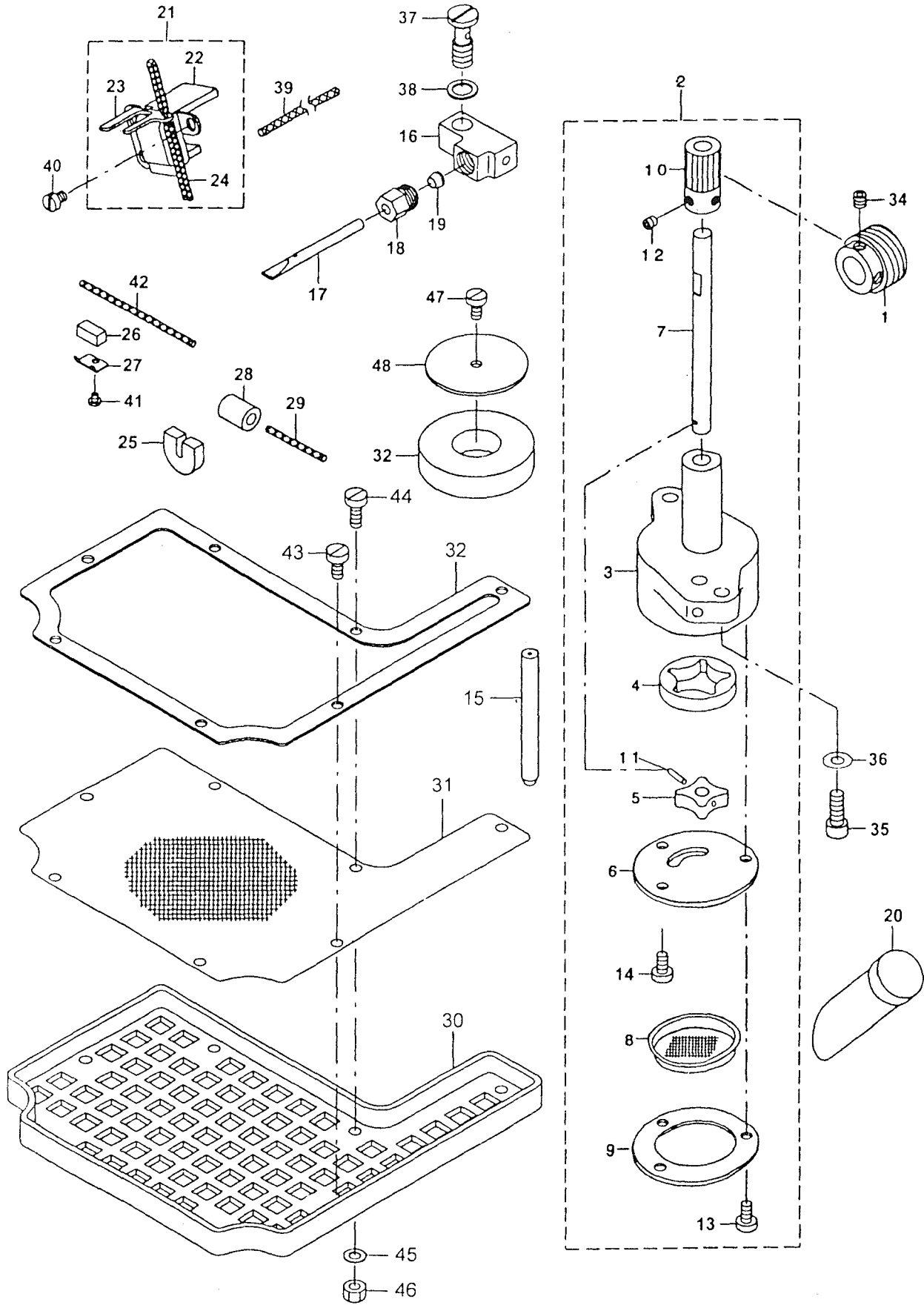

REF NO.	PART NO.	DESCRIPTION	Qty	NOTE
1	8041507	WORM	1	
2	8041663	OIL PUMP COMPL.	1	
3	8041665	OIL PUMP SAM.	(1)	
4	8041804	OIL PUMP GEAR OUTER RING	(1)	
5	8041903	OIL PUMP GEAR INNER RING	(1)	
6	8042000	OIL PUMP COVER	(1)	
7	8042109	OIL PUMP SHAFT	(1)	
8	8042307	OIL PUMP NET	(1)	
9	8042406	OIL PUMP NET PRESSER	(1)	
10	8042505	WORM GEAR	(1)	
11	8101001	PIN	(1)	
12	SM-8040412-TP	SET SCREW M4 L=4	(2)	
13	SM-6040800-SP	SCREW	(3)	
14	SM-6040800-SP	SCREW	(1)	
15	8042604	OILING EXIT PIPE	1	
16	8042752	OILING EXIT SUPPORT COMPL.	1	
17	8042802	OILING EXIT	1	
18	8042901	OILING EXIT JOINT A	1	
19	8043008	OILING EXIT JOINT B	1	
20	8043107	OIL GAUGE	1	
21	8043255	OIL FELT SAM.	1	
22	8043206	OIL FELT	(1)	
23	8043305	OIL FELT PRESSER	(1)	
24	CQ-2520000-OO	OIL WICK	(0.11)	
25	8043404	RETURNING OIL FILTER	1	
26	8043602	OIL FELT	1	
27	8043701	UPPER LOOPIER OIL FELT	1	
28	8043800	OIL SUPPLY BUSH	1	
29	CQ-2000000-OO	OIL WICK	0.03	
30	8044014	OIL RESERVOIR FILTER BASE	1	*
31	8044113	OIL RESERVOIR FILTER	1	*
32	8044212	FILTER PRESSER PLATE	1	*
33	8044303	MAGNET	1	
34	SM-8040412-TP	SCREW M5 L=5	2	
35	SM-6051402-TP	SCREW M5X0.8 L=14	2	
36	WP-0531000-SD	WASHER M5	2	
37	8113501	SCREW	1	
38	8103601	GASKET	1	
39	CQ-3030000-OO	OIL WICK	0.12	
40	8118104	SCREW	3	
41	SS-7060310-SP	SCREW 3/32-56 L=3	1	
42	CQ-2520000-OO	OIL WICK	0.06	
43	SM-6040800-SP	SCREW	2	
44	SM-6041000-SP	SCREW M4 L=10	5	
45	8110101	WASHER	5	
46	NM-6040003-SD	NUT M4	5	
47	SM-6040800-SP	SCREW	1	
48	8110507	WASHER	1	

12. KNIFE COMPONENTS

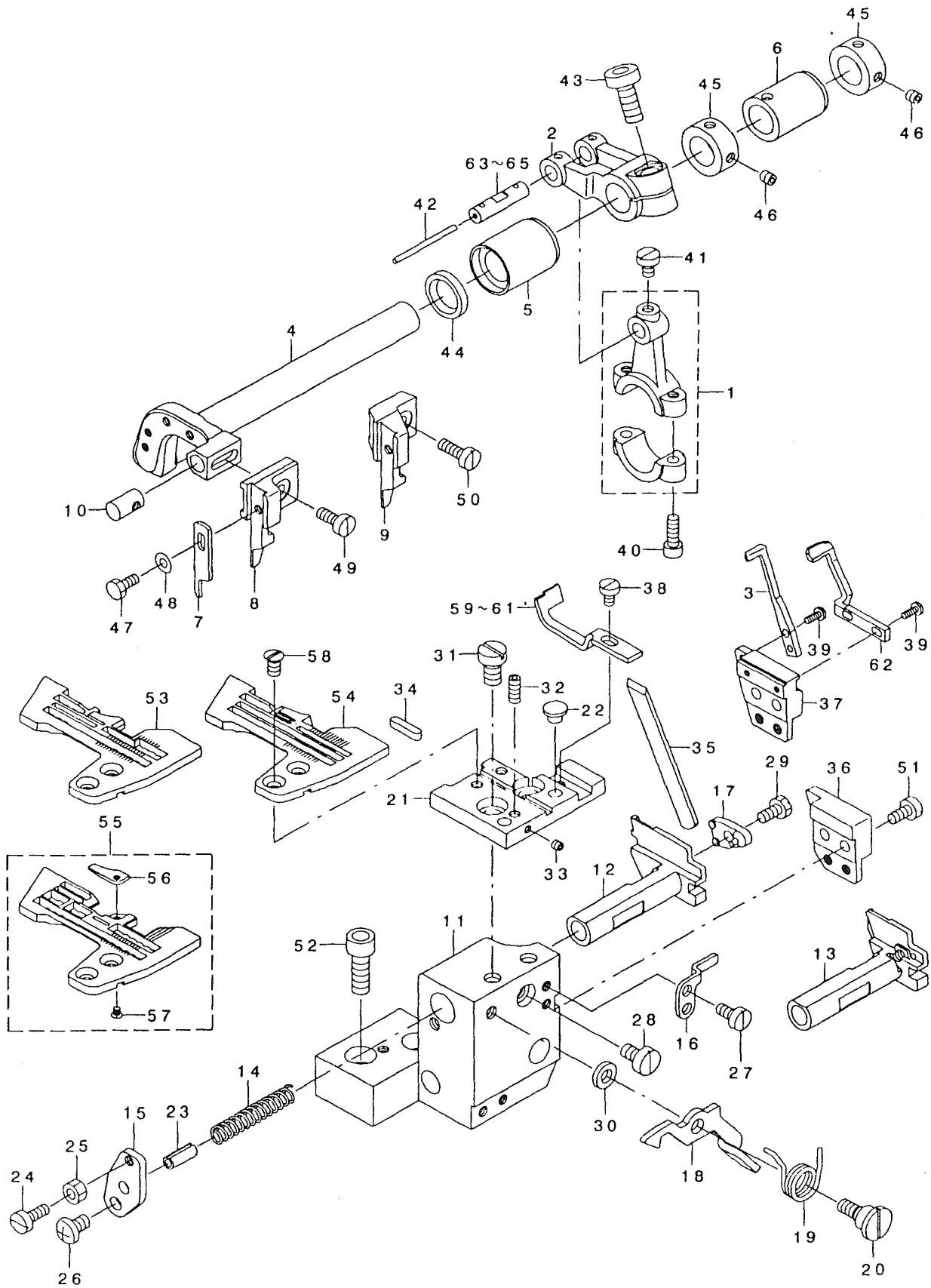

REF NO.	PART NO.	DESCRIPTION	Qty	NOTE	REF NO.	PART NO.	DESCRIPTION	Qty	NOTE
1	8045003	UPPER KNIFE ROD	1		34	8047405	THROAT PLATE POSITIONING KEY	1	
2	8045102	UPPER KNIFE FORK ARM	1		35	8047504	LOWER KNIFE	1	
3	8084705	CHAIN LOOPER NEEDLE GUARD	1	0 2	36	8046704	NEEDLE GUARD HOLDER	1	0 1
4	8045201	KNIFE DRIVING ARM SHAFT	1		37	8046803	NEEDLE GUARD HOLDER	1	0 2
5	8045300	BUSHING , FRONT	1		38	SS-3090610-SP	SCREW 9/64-40 L=6	1	*
6	8013001	BUSHING , REAR	1		39	8116009	SCREW	4	0 2
7	8045508	KNIFE	1		40	SM-6041202-TP	SCREW M4X0.7 L=12	2	
8	8045607	UPPER KNIFE SUPPORT	1	0 1	41	SM-6040600-SP	SCREW M4 L=6	1	
9	8045706	UPPER KNIFE SUPPORT	1	0 2	42	CQ-2000000-OO	OIL WICK	0.05	
10	8045805	UPPER KNIFE GUIDE SHAFT	1		43	SM-6061602-TP	SCREW M6 L=16	1	
11	8045904	LOWER KNIFE BRACKET	1		44	8105606	OIL SEAL	1	
12	8046001	LOWER KNIFE SLIDE STUD	1	0 1	45	8100409	THRUST COLLAR	2	
13	8046100	LOWER KNIFE SLIDE STUD	1	0 2	46	SM-8040412-TP	SET SCREW M4 L=4	4	
14	8046209	SPRING	1		47	SS-9090813-TP	SCREW 9/64-40 L=8	1	
15	8046308	STOPPER PLATE	1		48	WP-0370316-SD	WASHER 3.7X8X0.3	1	
16	8046407	ROTATING STOPPER	1		49	SM-6041000-SP	SCREW M4 L=10	1	0 1
17	8046605	LOWER KNIFE HOLDER	1		50	SM-6041200-SP	SCREW M4 L=12	1	0 2
18	8046902	LEVER	1		51	SM-6040800-SP	SCREW	2	
19	8047009	SPRING	1		52	SM-6061802-TP	SCREW M6 L=18	2	
20	8047108	HINGE SCREW	1		53	R4200-LOE-EOO	THROAT PLATE	1	0 3
21	8047207	THROAT PLATE BASE	1		54	R4305-LOE-EOO	THROAT PLATE	1	0 4
22	8047306	RUBBER PLUG A	2		55	R4508-LOE-GOO	THROAT PLATE	1	0 2
23	8101605	GUIDE PIN	1		56	8085009	THROAT PLATE CLAW	(1)	0 2
24	SM-6041000-SP	SCREW M4 L=10	1		57	SS-1060210-TP	SCREW 3/32-56 L=2.2	(1)	0 2
25	NM-6040003-SD	NUT M4	1		58	8116504	SCREW	2	
26	SM-4050855-SP	SCREW	1		59	8084101	NEEDLE GUARD	1	0 3
27	SM-6040800-SP	SCREW	2		60	8084200	NEEDLE GUARD	1	0 4
28	SM-6050800-SP	SCREW M5 L=8	1		61	8084408	CHAIN LOOPER NEEDLE GUARD	1	0 2
29	SM-9040800-SP	SCREW	1		62	8084507	CHAIN LOOPER NEEDLE GUARD	1	0 2
30	8110804	WASHER	1		63	8016202	CRANK PIN A	1	0 5
31	8120308	SCREW	2		64	8016400	CRANK PIN B	1	0 5
32	SM-8041012-TP	SCREW M4 L=10	1		65	8016509	CRANK PIN C	1	0 5
33	SM-8030312-TP	SCREW M3 L=3	1						

NOTE: 01...FOR GM288-3. GM288-4
02...FOR GM288-5
03...FOR GM288-3
04...FOR GM288-4
05...FOR SELECTIVE PART

13. SEMI-SUNKEN TYPE TABLE COMPONENTS

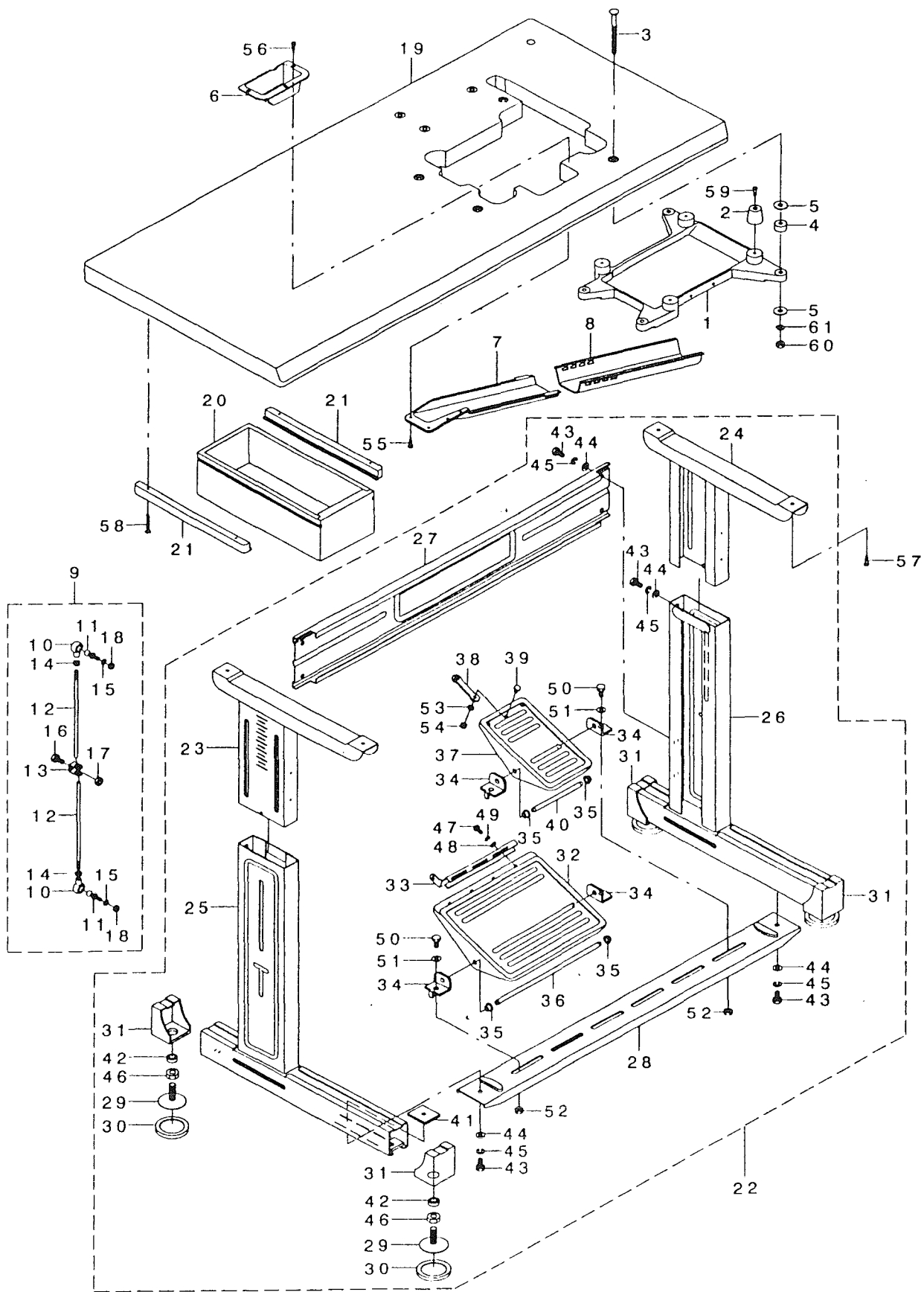

REF NO.	PART NO.	DESCRIPTION	Qty	NOTE	REF NO.	PART NO.	DESCRIPTION	Qty	NOTE
1	8048007	FRAME SUPPORT PLATE SAM.	1		32	8051852	PEDAL COMPL.	(1)	
2	8048106	RUBBER CUSHION	4		33	8052009	PEDAL ADJUSTING PLATE	(1)	
3	8048205	BOLT A	4		34	8052108	PEDAL SUPPORT	(4)	
4	8047900	BOLT SPACER	4		35	8052207	BUSHING	(4)	
5	8111307	WASHER	8		36	8052306	PEDAL SHAFT	(1)	
6	8049401	CLOTH WASTE CHUTE INLET	1		37	8052405	PRESSER LIFTING PEDAL	(1)	
7	8048502	CLOTH WASTE CHUTE (UPPER)	1		38	8052504	CHAIN HOOK	(1)	
8	8048601	CLOTH WASTE CHUTE (LOWER)	1		39	8052603	SCREW	(1)	
9	8048759	CONNECTING ROD JOINT SAM.	1	0 1	40	8052702	PEDAL SHAFT	(1)	
10	8048700	CONNECTING ROD JOINT	(2)		41	8052801	NUT	(2)	
11	8048809	CONNECTING ROD JOINT A	(2)		42	8052900	COLLAR	(4)	
12	8048908	CONNECTING ROD	(2)		43	8125307	BOLT	(16)	
13	8049005	CONNECTING BASE	(1)		44	8111109	WASHER	(16)	
14	8108808	NUT	(2)		45	8112206	SPRING WASHER	(16)	
15	8112107	SPRING WASHER	(2)		46	8109301	NUT	(4)	
16	8125307	BOLT	(1)		47	8124706	SCREW	(2)	
17	8109004	NUT	(1)		48	8110903	WASHER	(2)	
18	8108008	NUT	(2)		49	8112107	SPRING WASHER	(2)	
19	8049104	TABLE SAM. (SEMI-SUNKEN)	1	0 1	50	8125307	BOLT	(4)	
20	8049203	DRAWER	1	0 1	51	8111109	WASHER	(8)	
21	8049302	DRAWER SUPPORT	2	0 1	52	8109004	NUT	(4)	
22	8050052	T-STAND COMPL.	1	0 1	53	8112107	SPRING WASHER	(1)	
23	8050151	UPPER STAND COMPL. (LEFT)	(1)		54	8108808	NUT	(1)	
24	8050250	UPPER STAND COMPL. (RIGHT)	(1)		55	8126107	SCREW	4	
25	8050557	LOWER STAND COMPL. (LEFT)	(1)		56	8126602	SCREW	3	*
26	8050656	LOWER STAND COMPL. (RIGHT)	(1)		57	8126206	WOOD SCREW	4	0 1
27	8051209	SIDE STRUT	(1)		58	8126503	SCREW	4	0 1
28	8051308	LOWER STRUT	(1)		59	8113709	SCREW	4	
29	8051456	ADJUSTING SCREW COMPL.	(4)		60	8109004	NUT	4	
30	8051605	BASE CAP	(4)		61	8112206	SPRING WASHER	4	
31	8051704	STAND BASE CAP	(4)						

NOTE: 01....EXCLUDED WHEN DELIVERING HEAD ONLY

14. FULLY-SUNKEN TYPE TABLE COMPONENTS

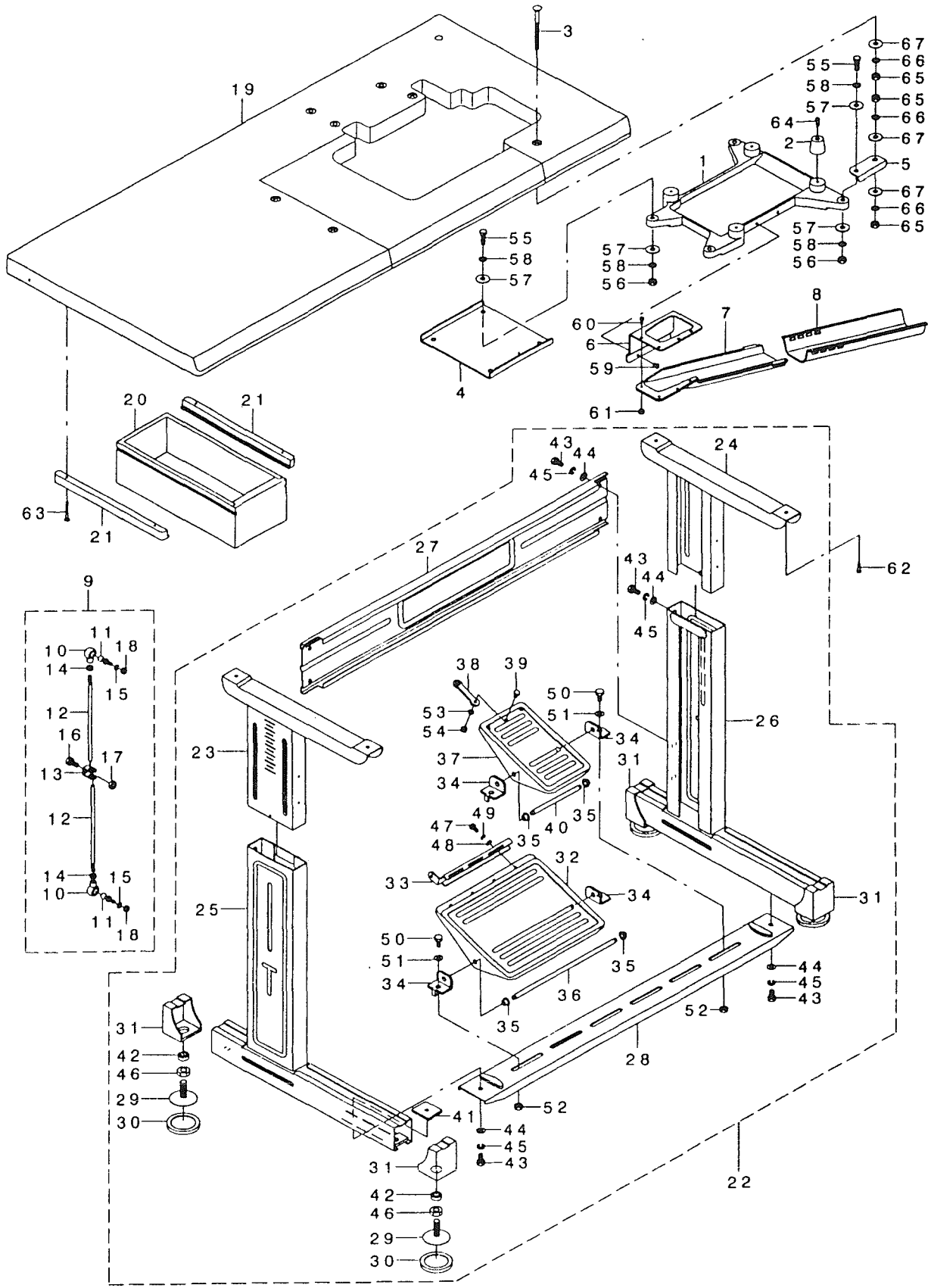

REF NO.	PART NO.	DESCRIPTION	Qty	NOTE	REF NO.	PART NO.	DESCRIPTION	Qty	NOTE
1	8048007	FRAME SUPPORT PLATE SAM.	1		35	8052207	BUSHING	(4)	
2	8048106	RUBBER CUSHION	4		36	8052306	PEDAL SHAFT	(1)	
3	8053205	BOLT B	4		37	8052405	PRESSER LIFTING PEDAL	(1)	
4	8053304	AUXILIART PLATE A	1		38	8052504	CHAIN HOOK	(1)	
5	8053403	AUXILIART PLATE B	1		39	8052603	SCREW	(1)	
6	8053502	SUPPORT PLATE	1		40	8052702	PEDAL SHAFT	(1)	
7	8048502	CLOTH WASTE CHUTE (UPPER)	1		41	8052801	NUT	(2)	
8	8048601	CLOTH WASTE CHUTE (LOWER)	1		42	8052900	COLLAR	(4)	
9	8048759	CONNECTING ROD JOINT SAM.	1	0 1	43	8125307	BOLT	(16)	
10	8048700	CONNECTING ROD JOINT	(2)		44	8111109	WASHER	(16)	
11	8048809	CONNECTING ROD JOINT A	(2)		45	8112206	SPRING WASHER	(16)	
12	8048908	CONNECTING ROD	(2)		46	8109301	NUT	(4)	
13	8049005	CONNECTING BASE	(1)		47	8124706	SCREW	(2)	
14	8108808	NUT	(2)		48	8110903	WASHER	(2)	
15	8112107	SPRING WASHER	(2)		49	8112107	SPRING WASHER	(2)	
16	8125307	BOLT	(1)		50	8125307	BOLT	(4)	
17	8109004	NUT	(1)		51	8111109	WASHER	(8)	
18	8108808	NUT	(2)		52	8109004	NUT	(4)	
19	8053650	TABLE SAM. , FULLY-SUNKEN TYPE	1	0 1	53	8112107	SPRING WASHER	(1)	
20	8049203	DRAWER	1	0 1	54	8108808	NUT	(1)	
21	8049302	DRAWER SUPPORT	2	0 1	55	8125406	BOLT	3	
22	8050052	T-STAND COMPL.	1	0 1	56	8109004	NUT	3	
23	8050151	UPPER STAND COMPL. (LEFT)	(1)		57	8111307	WASHER	6	
24	8050250	UPPER STAND COMPL. (RIGHT)	(1)		58	8112206	SPRING WASHER	6	
25	8050557	LOWER STAND COMPL. (LEFT)	(1)		59	SM-4050855-SP	SCREW	2	
26	8050656	LOWER STAND COMPL. (RIGHT)	(1)		60	SM-6041200-SP	SCREW	4	
27	8051209	SIDE STRUT	(1)		61	8108303	NUT	4	
28	8051308	LOWER STRUT	(1)		62	8126206	WOOD SCREW	4	0 1
29	8051456	ADJUSTING SCREW COMPL.	(4)		63	8126503	SCREW	4	0 1
30	8051605	BASE CAP	(4)		64	8113709	SCREW	4	
31	8051704	STAND BASE CAP	(4)		65	8109004	NUT	12	
32	8051852	PEDAL COMPL.	(1)		66	8112206	SPRING WASHER	12	
33	8052009	PEDAL ADJUSTING PLATE	(1)		67	8111307	WASHER	12	
34	8052108	PEDAL SUPPORT	(4)						

NOTE: 01...EXCLUDED WHEN DELIVERING HEAD ONLY

15. THREAD STAND COMPONENTS

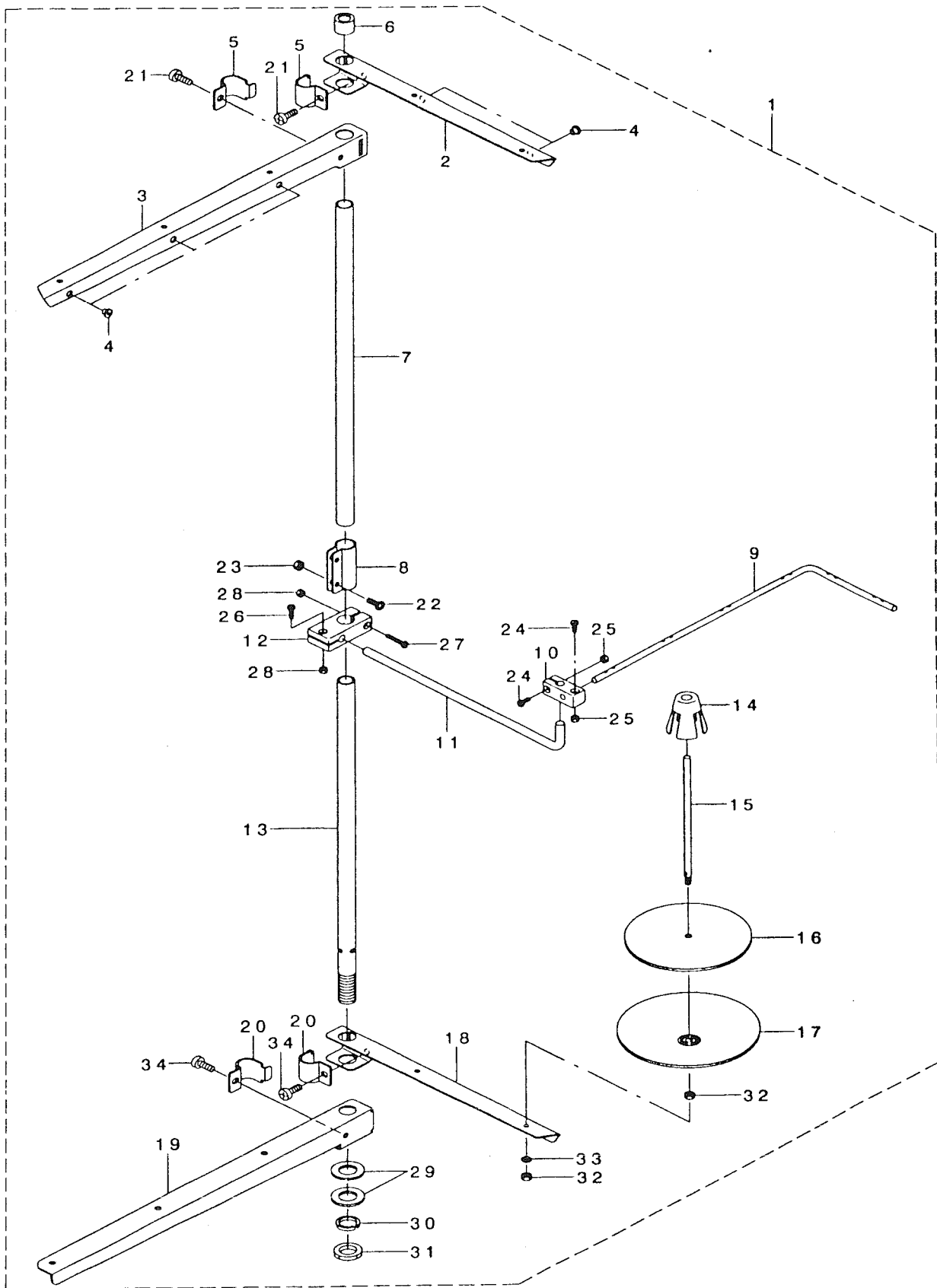

REF NO.	PART NO.	DESCRIPTION	Qty	NOTE
1	8060150	THREAD STANDING DEVICE SAM.	1	
2	8330507	SPOOL REST ARM	(1)	
3	8061703	SPOOL REST ARM , LONG	(1)	
4	8331208	THREAD GUIDE	(5)	
5	8330705	THREAD GUIDE ARM JOINT	(2)	
6	8331406	SPOOL REST ROD RUBBER CAP	(1)	
7	8330408	SPOOL REST ROD , UPPER	(1)	
8	8331307	SPOOL REST ROD JOINT	(1)	
9	8060705	SPOOL REST ROD , LOWER	(1)	
10	8060804	LOWER SPOOL REST ROD BASE	(1)	
11	8060903	THREAD GUIDE ARM	(1)	
12	8061000	THREAD GUIDE ARM BASE	(1)	
13	8330309	SPOOL REST ROD , LOWER	(1)	
14	8331109	SPOOL RETAINER	(5)	
15	8331000	SPOOL PIN	(5)	
16	8330903	SPOOL REST CUSHION	(5)	
17	8330804	SPOOL REST	(5)	
18	8330507	SPOOL REST ARM	(1)	
19	8061703	SPOOL REST ARM , LONG	(1)	
20	8330705	THREAD GUIDE ARM JOINT	(2)	
21	SM-6061610-SC	SCREW M6 L=16	(2)	*
22	SM-4051405-SE	SCREW M5 L=14	(2)	
23	NM-6050001-SE	NUT M5	(2)	
24	8118302	SCREW	(2)	
25	8108303	NUT	(2)	
26	8118401	SCREW A	(1)	
27	8118500	SCREW B	(1)	
28	8108303	NUT	(2)	
29	WP-1702600-SO	WASHER 17X30X2.6	(2)	
30	WS-1643202-KR	SPRING WASHER	(1)	
31	NM-6160511-SE	NUT M16X1.5	(1)	
32	NM-6050001-SE	NUT M5	(5)	
33	WS-0510002-KN	SPRING WASHER	(5)	
34	SM-6061610-SC	SCREW M6 L=16	(2)	

16. NEEDLE COOLER COMPONENTS

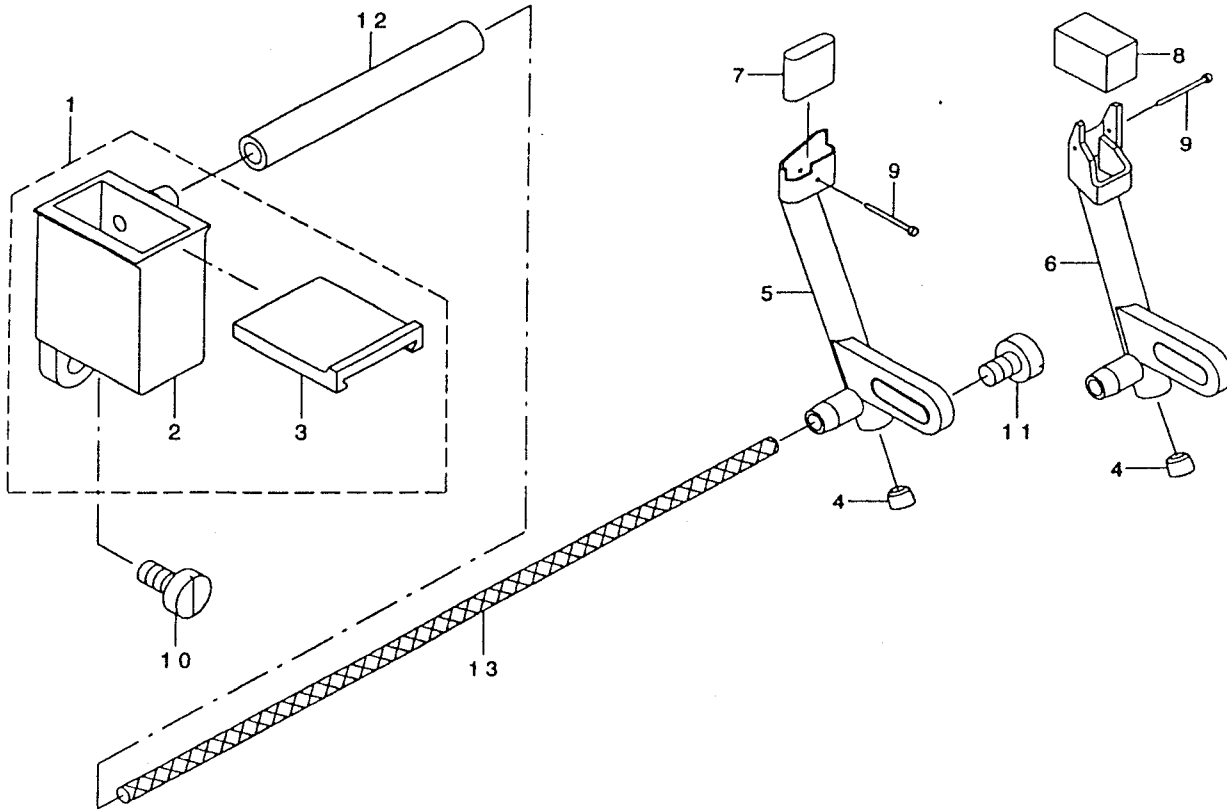

REF NO.	PART NO.	DESCRIPTION	Qty	NOTE
1	8058550	NEEDLE COOLER TANK SAM.	1	
2	8058501	NEEDLE COOLER TANK	(1)	
3	8058600	TANK COVER	(1)	
4	8106505	PLUG	1	
5	8058709	NEEDLE COOLER UNIT (OVER)	1	01
6	8058804	NEEDLE COOLER UNIT (INTER)	1	02
7	8059103	NEEDLE COOLER FELT	1	01
8	8058907	NEEDLE COOLER FELT	1	02
9	8059004	NEEDLE COOLER FELT PRESSER	1	
10	SM-6040800-SP	SCREW	1	
11	SM-6040600-SP	SCREW M4 L=6	2	
12	8102603	NEEDLE COOLER PIPE	0.05	
13	8102405	NEEDLE COOLER OIL WICK	0.15	

NOTE: 01....FOR GM288-3, GM288-4

02....FOR GM288-5

17. ACCESSORIE PART COMPONENTS

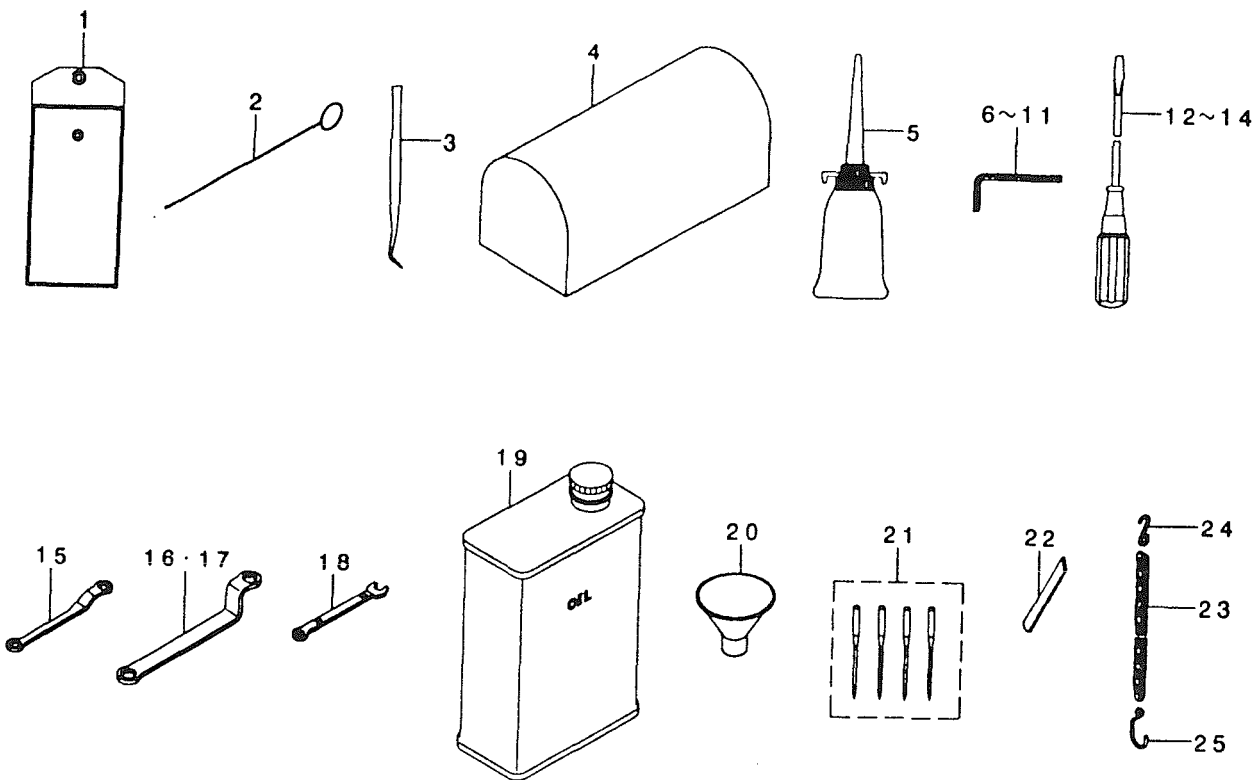

REF NO.	PART NO.	DESCRIPTION	Qty	NOTE
1	8055002	ACCESSORY PACK	1	
2	8055101	THREADER	1	
3	8055200	TWEEZERS	1	
4	8055309	VINYL HEAD COVER	1	
5	8055408	OILER	1	
6	8056802	HEXAGONAL WRENCH , 1.5	1	
7	8055606	HEXAGONAL WRENCH , 2.0	1	
8	8055705	HEXAGONAL WRENCH , 2.5	1	
9	8055804	HEXAGONAL WRENCH , 3.0	1	
10	8055903	HEXAGONAL WRENCH , 4.0	1	
11	8056000	HEXAGONAL WRENCH , 5.0	1	
12	8056109	SCREWDRIVER , SMALL	1	
13	8056208	SCREWDRIVER , MIDDLE	1	
14	8056307	SCREWDRIVER , LARGE	1	
15	8056505	SPECTALE WRENCH , 7×7	1	
16	8056406	SPECTALE WRENCH , 5.5	1	
17	8056703	SPECTALE WRENCH , 9.0	1	
18	8057701	WRENCH , 5×6	1	
19	8057107	OIL	1	
20	8057206	FUNNEL	1	
21	MDC-270B1104	NEEDLE DC×27#11-4EA	1	
22	8047504	LOWER KNIFE	1	
23	8057404	CHAIN	1	
24	8057503	S-SHAPED MFTAL FITTING , SMALL	1	
25	8057602	S-SHAPED MFTAL FITTING , LARGE	1	

SHANGHAI HUIGONG SEWING MACHINE NO.3 FACTORY

ADD: 1418, Yishan Road, Shanghai, China

Zip Code: 201103

TEL: (021)64061284 64654014

FAX: (021)64462799

E-mail: Highlead@online.sh.cn

<http://highlead.com.cn>